

Activity 52

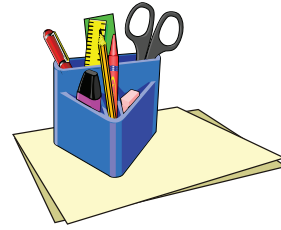

OBJECTIVE

To obtain a formula for the area of a circle

MATERIAL REQUIRED

Cardboard, white drawing sheet, compasses, pencil, colours, adhesive, scissors.

METHOD OF CONSTRUCTION

1. Take a cardboard of convenient size and paste a white sheet on it.
2. Draw two identical circles of radius ' a ' (say 6 cm) (Fig. 1).
3. Make cutouts of these two circles.
4. Fold the circles as shown in Fig. 2.

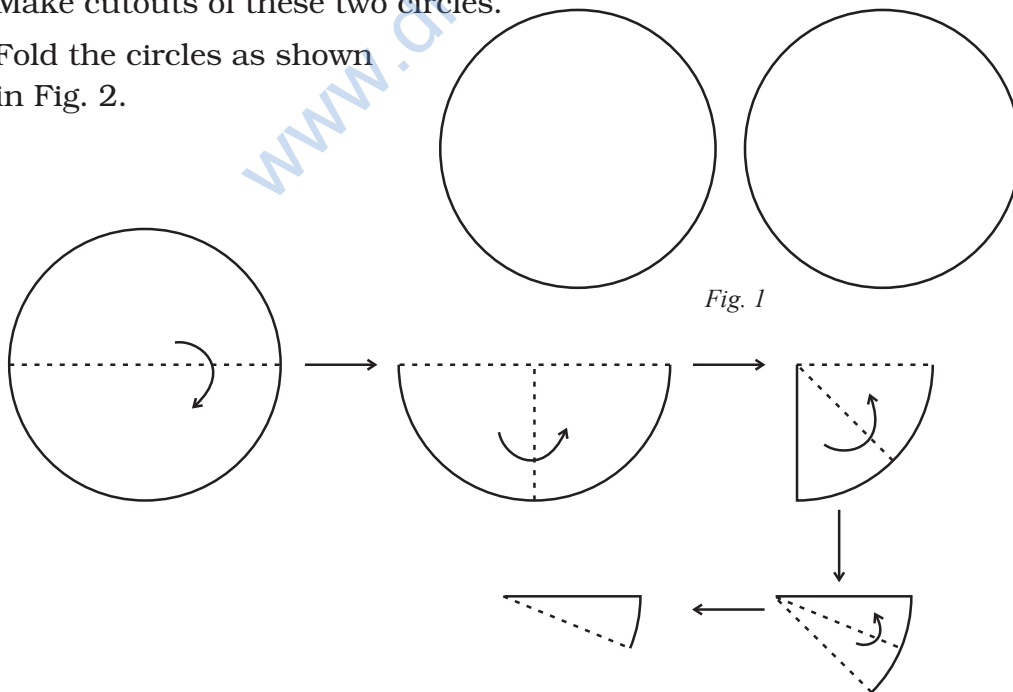

Fig. 2

Fig. 1

5. Unfold both the circles and colour the sixteen parts so obtained as shown in Fig. 3.

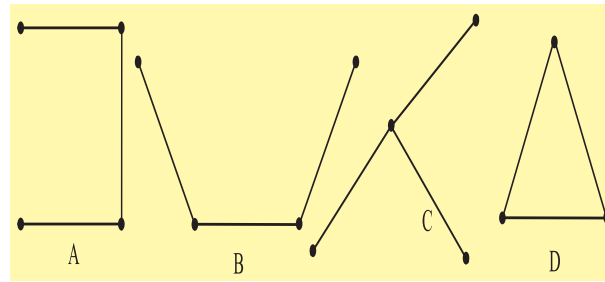

Fig. 3

6. Paste one of the circles on the cardboard sheet (Fig. 4).

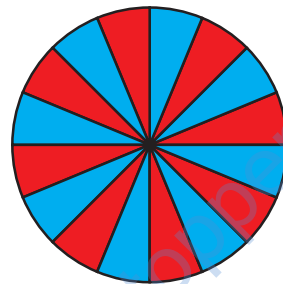

Fig. 4

7. Cut out neatly all sixteen parts from the other circle.
8. Arrange and paste them neatly as shown in Fig. 5.

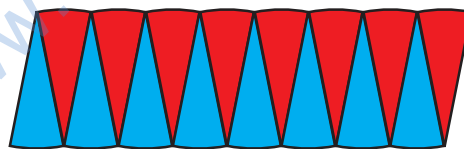

Fig. 5

DEMONSTRATION

- The given figure looks like a rectangle.
- Length of the rectangle = $\frac{1}{2}$ of circumference of the circle

$$= \frac{1}{2} \times (2\pi r)$$

$$= \pi r.$$

3. Breadth of the rectangle = radius of the circle = r

$$\begin{aligned}\text{Therefore, area of the circle} &= \text{Area of the rectangle} \\ &= l \times b \\ &= \pi r \times r \\ &= \pi r^2.\end{aligned}$$

OBSERVATION

On actual measurement:

Radius of the circle = _____.

So, circumference of the circle = _____.

Length of rectangle in Fig. 5 = _____.

Breadth of rectangle in Fig. 4 = _____.

Area of rectangle in Fig. 5 = _____.

Area of circle in Fig. 3 = _____.

APPLICATION

This result is useful in finding area of any circular object.

Activity 53

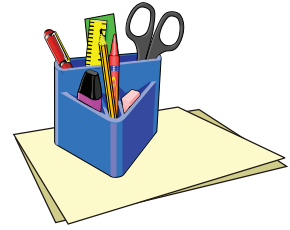

OBJECTIVE

To verify that vertically opposite angles are equal

MATERIAL REQUIRED

Cardboard, two straws, 360° protractor thumb pin, white paper.

METHOD OF CONSTRUCTION

1. Take a cardboard of convenient size and paste a white paper on it.
2. Take two straws and a 360° protractor and fix them on the cardboard using a thumb pin at the centre of the protractor as shown in Fig. 1.
3. Mark the end points of the straws as A, B, C and D either using paper chit's or using marker (see Fig. 1).

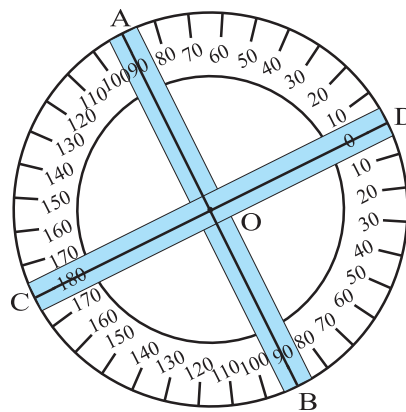

Fig. 1

DEMONSTRATION

1. Rotate the straws and note the measures of the angles AOC, BOC, BOD and AOD in different positions with the help of the protractor fixed.
2. From the measurements, $\angle AOD = \angle COB$ and $\angle AOC = \angle DOB$.

Thus, vertically opposite angles are equal.

OBSERVATION

Complete the following table:

Position	$\angle AOC$	$\angle BOC$	$\angle BOD$	$\angle AOD$	
1	_____	_____	_____	_____	$\angle AOC = \dots\dots$, $\angle BOC = \dots\dots$
2	_____	_____	_____	_____	$\dots\dots = \angle BOD$, $\dots\dots = \angle AOD$
3	_____	_____	_____	_____	$\angle \dots\dots = \angle \dots\dots =$, $\angle \dots\dots = \angle \dots\dots$
⋮					

Thus, vertically opposite angles are _____.

APPLICATION

This result can be used to explain

1. Property of a linear pair.
2. Meaning of vertically opposite angles.

Activity 54

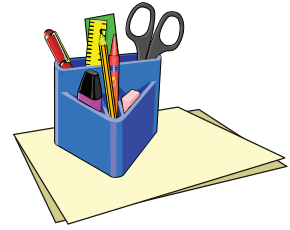

OBJECTIVE

To add two algebraic expressions (polynomials) using different strips of cardboard.

MATERIAL REQUIRED

Cardboard, coloured papers (green, blue and red), geometry box, cutter, eraser, adhesive, sketch pen.

METHOD OF CONSTRUCTION

1. Take three pieces of cardboards and paste coloured papers on them. Green on one, blue on the second and red on the last one.
2. Make sufficiently large number of squares (strips) of side x units on green paper and cut them out [Fig. 1].
3. Similarly, draw rectangle of dimensions $x \times 1$ on blue coloured paper and square of dimensions 1×1 unit on red coloured paper and cut them out [Fig. 2 and Fig. 3].



x
Fig. 1

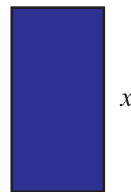

x
1
Fig. 2



1
Fig. 3

DEMONSTRATION

- To represent the algebraic expression $3x^2 + 2x + 5$, arrange the strips as shown in (Fig. 4).

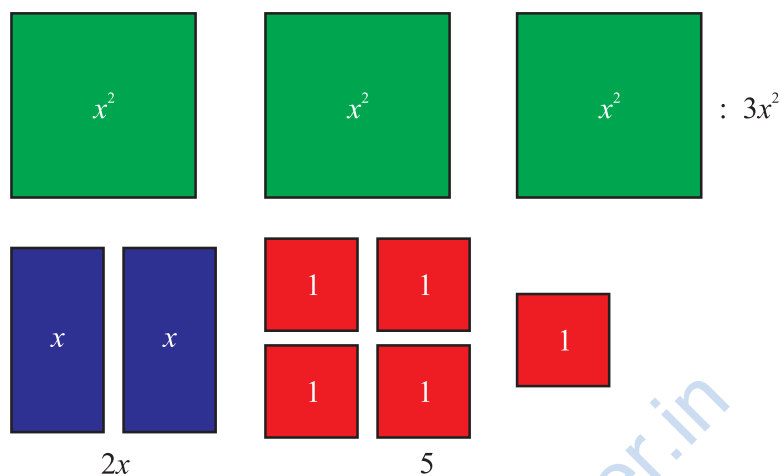

Fig. 4

- Similarly, as in step 1, represent the algebraic expression $2x^2 + 4x + 2$ as follows (Fig. 5).

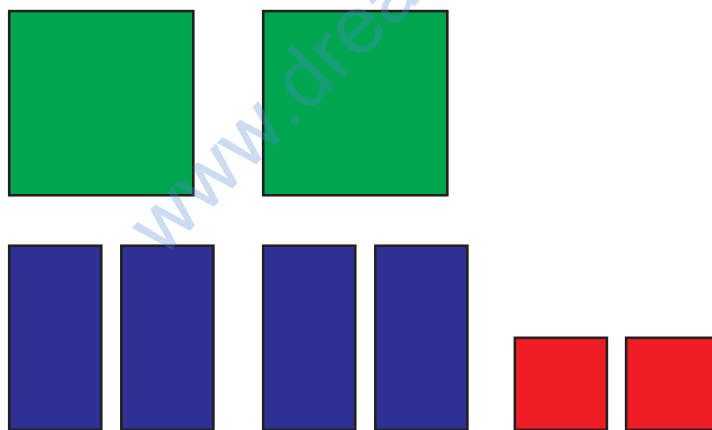

Fig. 5

- To add the above two expressions, combine the strips in Fig. 4 and Fig. 5 as shown below (Fig. 6).

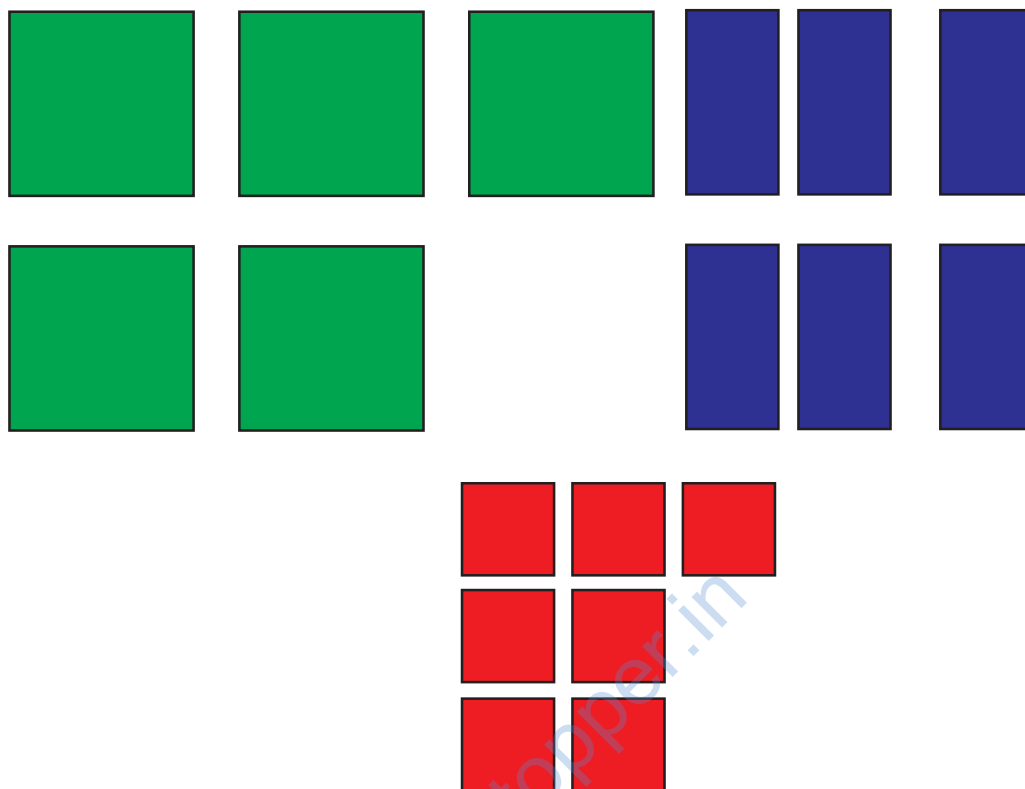

Fig. 6

4. Count the strips of each colour in Fig. 6. We find that it consists of 5 green strips, 6 blue strips and 7 red strips. This represents the sum of two algebraic expressions as mentioned above as $5x^2 + 6x + 7$

Similarly, find the sum of some other two algebraic expressions.

OBSERVATION

1. In Fig. 4
 - (a) Number of green strips = _____.
 - (b) Number of blue strips = _____.
 - (c) Number of red strips = _____.
 - (d) Algebraic expression represented = _____.
2. In Fig. 5
 - (a) Number of green strips = _____.

(b) Number of blue strips = _____.

(c) Number of red strips = _____.

(d) Algebraic expression represented = _____.

3. In Fig. 6

(a) Number of green strips = _____.

(b) Number of blue strips = _____.

(c) Number of red strips = _____.

(d) Algebraic expression represented = _____.

Thus $(3x^2 + 2x + 5) + (2x^2 + 4x + 2)$ = _____ + _____ + _____.

APPLICATION

The activity is useful in explaining the concept of addition of two algebraic expressions as well as like and unlike terms.

www.dreamtopper.in



Activity 55

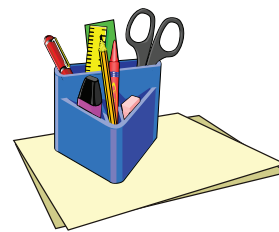

OBJECTIVE

To subtract a polynomial from another polynomial [for example, $(2x^2 + 5x - 3) - (x^2 - 2x + 4)$]

MATERIAL REQUIRED

Blue and red colours, scissors, ruler, eraser, white chart paper.

METHOD OF CONSTRUCTION

1. Make sufficient number of cutouts of dimensions $3\text{ cm} \times 3\text{ cm}$, $3\text{ cm} \times 1\text{ cm}$ and $1\text{ cm} \times 1\text{ cm}$ as shown in Fig. 1.

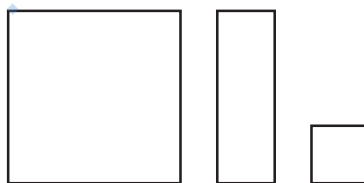

Fig. 1

2. Colour one side of each shape by red colour, and the other by blue colour.
3. Let blue coloured cut out of size $3\text{ cm} \times 3\text{ cm}$ represent x^2 , cut out of size $3\text{ cm} \times 1\text{ cm}$ represent x and cut out of size $1\text{ cm} \times 1\text{ cm}$ represent $+1$.
4. Similarly, let corresponding red coloured cutouts represent $-x^2$, $-x$ and -1 , respectively.

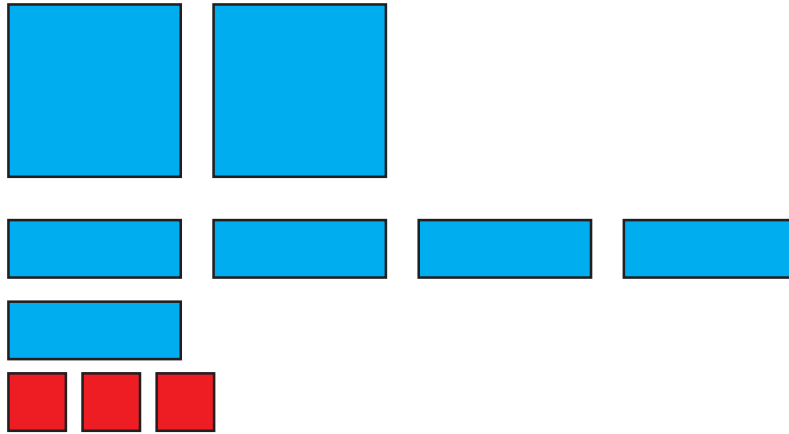

Fig. 2

DEMONSTRATION

1. The polynomial $2x^2 + 5x - 3$ is represented in Fig. 2.
2. The polynomial $(x^2 - 2x + 4)$ is represented in Fig. 3.

To subtract the polynomial $x^2 - 2x + 4$ from $2x^2 + 5x - 3$, we have to remove 2nd set of algebraic pieces (Fig. 3). Invert each cut out of Fig. 3 and place it along the cutouts of Fig. 2 as shown in Fig. 4.

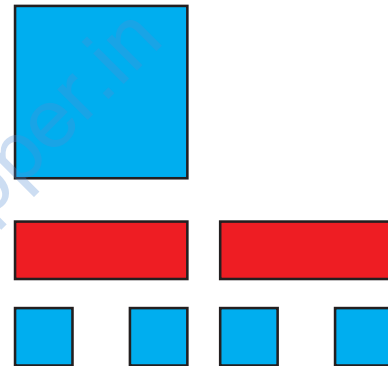

Fig. 3

4. Cancel one blue cut out with one red cut out of same size, if any, as shown in Fig. 4.

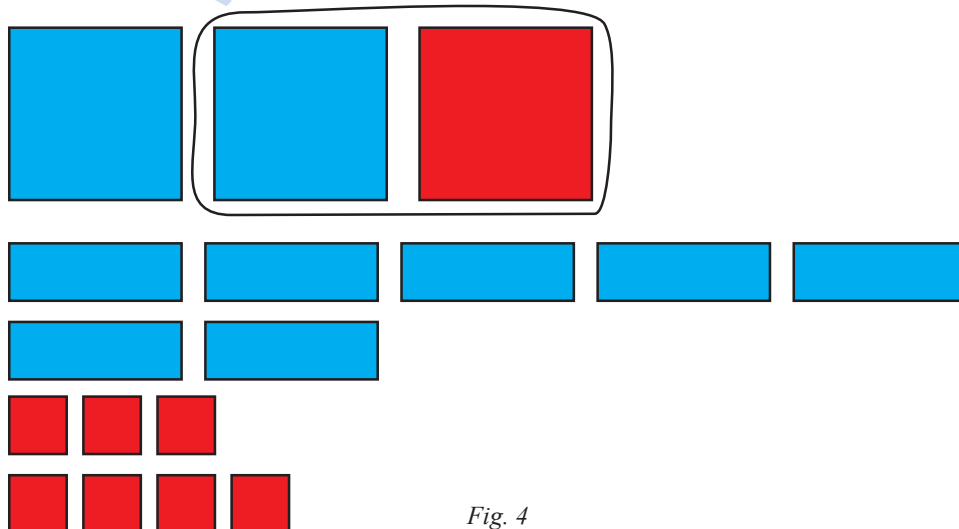

Fig. 4

5. Remaining cut outs represent the polynomial

$$x^2 + 7x - 7$$

6. So, $(2x^2 + 5x - 3) - (x^2 - 2x + 4) = x^2 + 7x - 7$

This result may be checked by finding

(i) $(x^2 + 7x - 7) + (x^2 - 2x + 4) = 2x^2 + 5x - 3$

(ii) $(2x^2 + 5x - 3) - (x^2 + 7x - 7) = x^2 - 2x + 4$

through suitable activities.

OBSERVATION

1. In Fig. 2, the polynomial represented is _____.
2. In Fig. 3, the polynomial represented is _____.
3. In Fig. 4, the polynomial represented is _____.
4. So, $(2x^2 + 5x - 3) - (x^2 - 2x - 1) = \underline{\quad} + \underline{\quad} - 7$.

APPLICATION

This activity is useful in explaining subtraction of polynomials, and also the concept of like and unlike terms.

www.dreamtopper.in



Activity 56

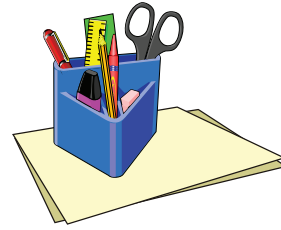

OBJECTIVE

To collect data and represent this through a bar graph

MATERIAL REQUIRED

An English textbook, pen/pencil, graph paper/grid paper, different colours, ruler.

METHOD OF CONSTRUCTION

1. Divide the class into groups of 4 or 5 students.
2. Let a student of one group open a page of English textbook randomly and record the number of times different vowels *a*, *e*, *i*, *o*, *u* occur on that page.
3. The other group members will help her in counting vowels. Each group may record the data in the table below.

Vowel	Tally marks	Number of times a vowel occurs on that page
<i>a</i>		
<i>e</i>		
<i>i</i>		
<i>o</i>		
<i>u</i>		
		Total

4. Take a cardboard and paste a grid paper on it.

5. Draw two perpendicular lines on it, through a point say O.
6. Write 'vowels' along the horizontal line and 'number of times a vowel occurs' (frequency) along the vertical axis.
7. Draw bars for each vowel according to its frequency.
8. Colour the bars differently.

DEMONSTRATION

1. The above table represents the frequency distribution of vowels.
2. The graph obtained after drawing bars in step 6 will be a bar graph representing occurrence of vowels on a page.

This activity will be performed by all the groups and separate bar graphs may be drawn by each group.

Data collected by each student may be combined together and a bar graph may be prepared for the data so obtained.

OBSERVATION

The vowel which occurs maximum number of times is _____.

The vowel which occurs minimum number of times is _____.

Mode of the data is _____.

APPLICATION

This activity may be used in understanding the meaning of data, frequency distribution, bar graph and mode of the data.



Activity 57

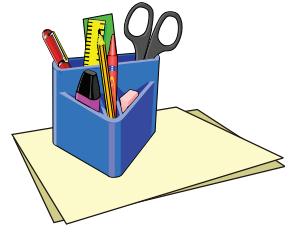

OBJECTIVE

To verify that a minimum of three sides are required to construct a polygon

MATERIAL REQUIRED

Cardboard, sticks, adhesive, coloured paper.

METHOD OF CONSTRUCTION

1. Take a cardboard of convenient size and cover it with a coloured paper.
2. Take two sticks and place them end-to-end in different positions. Some positions are shown in Fig. 1.

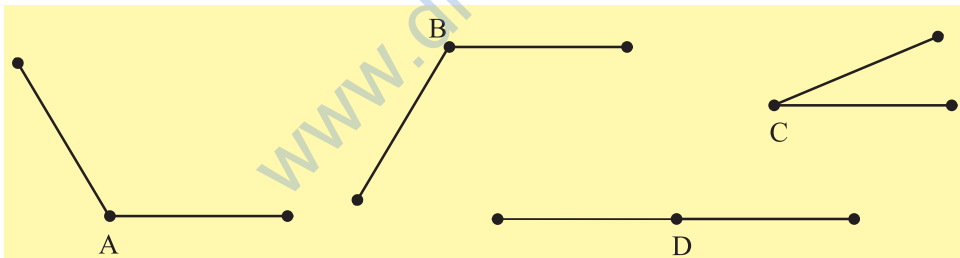

Fig. 1

3. Take three sticks and place them in different positions. Some positions are shown in Fig. 2.

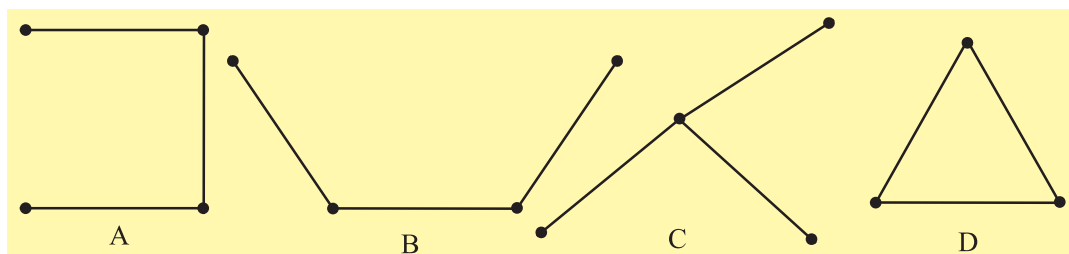

Fig. 2

4. Take four sticks and try to place them in different positions. Some of them are shown in Fig. 3.

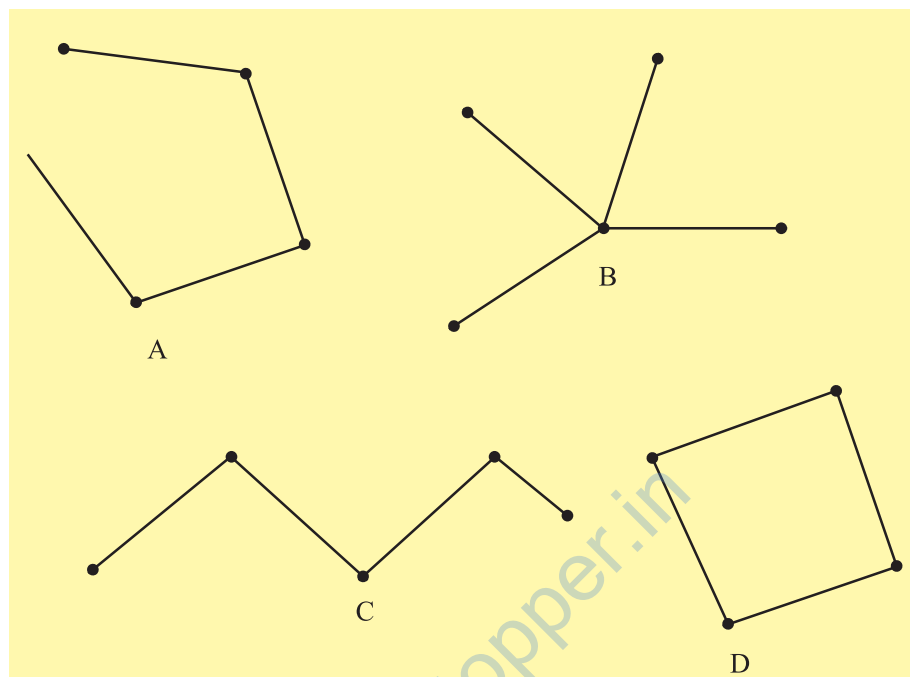

Fig. 3

5. Repeat the activity with more number of sticks.

DEMONSTRATION

1. No closed figure is formed with two sticks.
2. Closed figure is formed with three sticks.
3. Closed figure is formed with four sticks.
4. Closed figure is formed with five sticks and so on.

OBSERVATION

1. The closed figure formed with these sticks (line segments) is a polygon, called _____.
2. The closed figure formed with four line segments is a polygon, called _____.

3. The closed figure formed with five line segments is a polygon called _____.
4. No polygon is formed with _____ sticks (line segments) thus, a minimum of _____ line segments are needed to form a figure made up of line _____, i.e. a _____.

APPLICATION

This activity may be useful in understanding the construction of a polygon.

www.dreamtopper.in



Activity 58

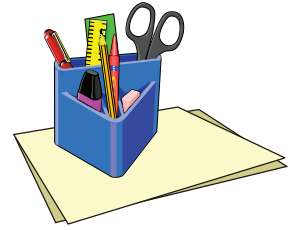

OBJECTIVE

To make medians of a triangle by paper folding

MATERIAL REQUIRED

Coloured paper, pencil, cardboard, scissors, adhesive, ruler.

METHOD OF CONSTRUCTION

1. Make a triangle ABC by paper folding or draw a triangle ABC. Cut it out (Fig.1).
2. Get the mid point of side BC by folding the paper such that B falls on C. Name this point D as shown in Fig. 2.

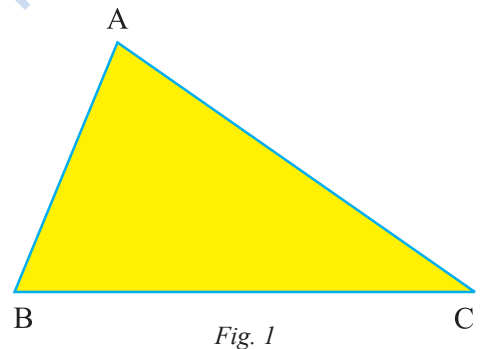

Fig. 1

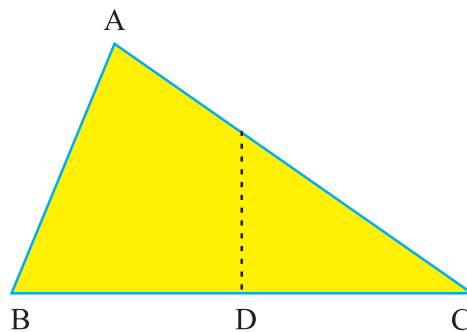

Fig. 2

3. Fold the triangle such that fold passes through A and D. Unfold and mark the crease with pencil as in Fig. 3.

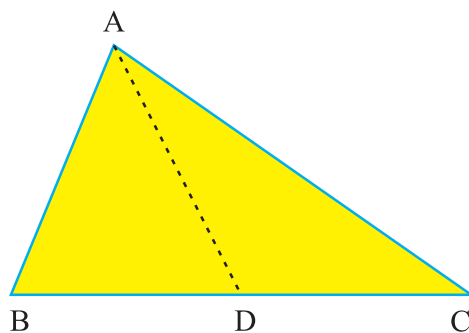

Fig. 3

4. Similarly, get the mid point E and F of sides AB and AC, respectively by paper folding. Join CE and BF by paper folding (Fig. 4).

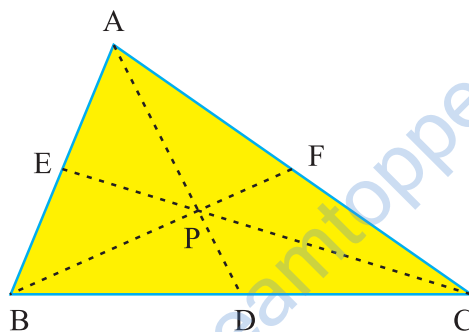

Fig. 4

DEMONSTRATION

1. AD, BF and CE are the medians of ΔABC .
2. They meet at a point P.

OBSERVATION

1. On actual measurement (in centimetres)

BD = _____, CD = _____.

BE = _____, AE = _____.

CF = _____, AF = _____.

$$AD = \underline{\hspace{2cm}}, \quad PD = \underline{\hspace{2cm}}.$$

$$CP = \underline{\hspace{2cm}}, \quad PE = \underline{\hspace{2cm}}.$$

$$BP = \underline{\hspace{2cm}}, \quad PF = \underline{\hspace{2cm}}.$$

$$BD = \underline{\hspace{2cm}}, \quad CD = \underline{\hspace{2cm}}.$$

$$\frac{AP}{AD} = \frac{BP}{PF} = \frac{CP}{PE} = \underline{\hspace{2cm}}.$$

2. All the three medians pass through the same point.
3. This point lies in the interior of the triangle.

APPLICATION

The activity is useful in understanding the meaning of the medians of a triangle. Also in understanding an important result that all the medians meet at a point and this point divides each of these in the ratio 2 : 1.

NOTE

1. Do this activity for all types of triangles namely right angled triangle and obtuse angled triangle and see that in each case the three medians meet in the interior of the triangle.

www.dreamtopper.in



Activity 59

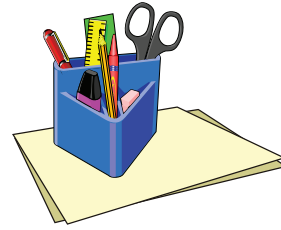

OBJECTIVE

To obtain a formula for area of a rhombus

MATERIAL REQUIRED

Coloured paper, adhesive, scissors, cardboard, pen, pencil.

METHOD OF CONSTRUCTION

1. Take a coloured paper and make a rhombus through paper folding or draw a rhombus on a paper.
2. Cut it out and paste it on a cardboard and name it as ABCD (Fig. 1).
3. Make a trace copy of this figure.
4. Obtain diagonals AC and DB of the trace copy by paper folding and then cut it through AC and DB to get four triangles as shown in Fig. 2.

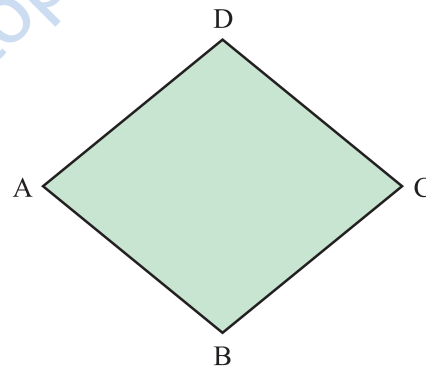

Fig. 1

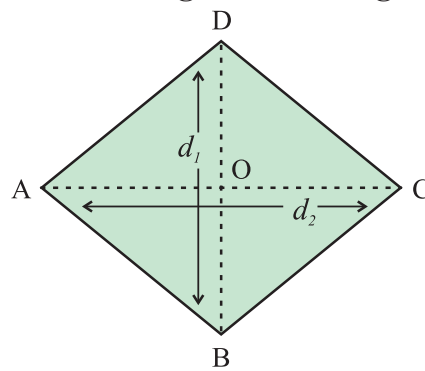

Fig. 2

5. Make replicas of $\triangle DOC$, $\triangle DOA$, $\triangle AOB$ and $\triangle BOC$

DEMONSTRATION

1. Arrange the replicas of triangles as shown in Fig. 3.
2. EFGH is a rectangle.
3. Diagonal AC is equal to the length of the rectangle EFGH.
4. Diagonal DB is equal to the breadth of the rectangle EFGH.

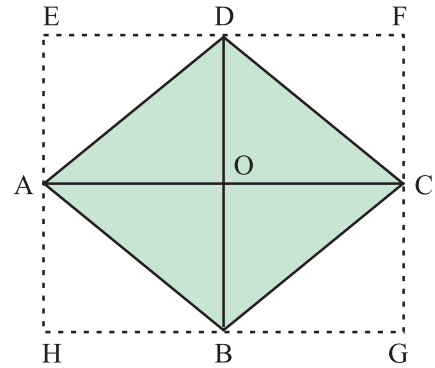

Fig. 3

5. Area of rhombus $= \frac{1}{2} \times$ area of rectangle
 $= \frac{1}{2} \times$ length \times breadth
 $= \frac{1}{2} \times d_1 \times d_2$
 $= \frac{1}{2} \times$ product of diagonals.

OBSERVATION

On actual measurement:

$$d_1 = \text{_____}, d_2 = \text{_____}.$$

$$\text{So, } d_1 \times d_2 = \text{_____}, \frac{d_1 \times d_2}{2} = \text{_____}.$$

$$\text{Area of rectangle EFGH} = \text{_____}.$$

$$\text{Area of rhombus ABCD} = \frac{1}{2} \text{ area of rectangle } \text{_____}.$$

$$= \frac{1}{2} d_1 \times \text{_____}.$$

APPLICATION

This activity can be used in explaining formula for area of a rhombus.

Activity 60

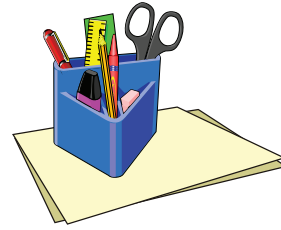

OBJECTIVE

To verify Pythagoras Theorem for any right triangle

MATERIAL REQUIRED

Cardboard, coloured papers, adhesive, scissors, geometry box, sketch pens, tracing paper.

METHOD OF CONSTRUCTION

1. Take a piece of cardboard of convenient size and paste a white paper on it.
2. Make cut outs of eight identical right triangles of which four are of one colour (blue) and four are of another colour (red) of convenient size each having sides a , b and c (say 3 cm, 4 cm and 5 cm, respectively) (see Fig. 1).
3. Make two identical squares each of side $a + b$ (Fig. 2).

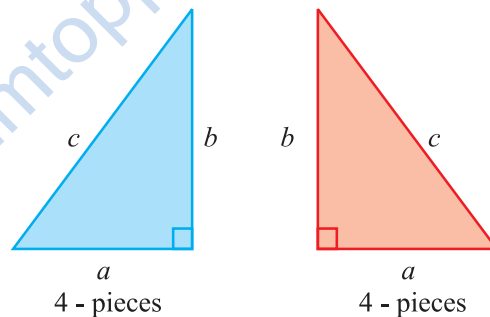
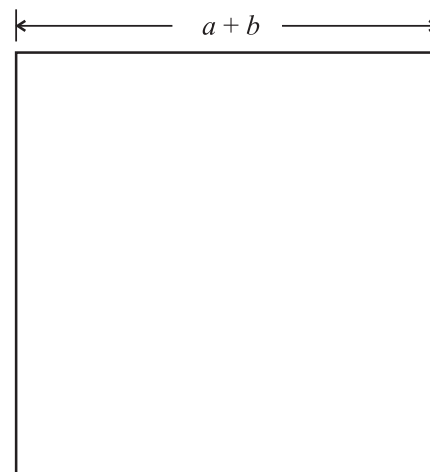

Fig. 1



2 - pieces
Fig. 2

DEMONSTRATION

1. Arrange four right triangles of blue colour in one of the squares as shown in Fig. 3.

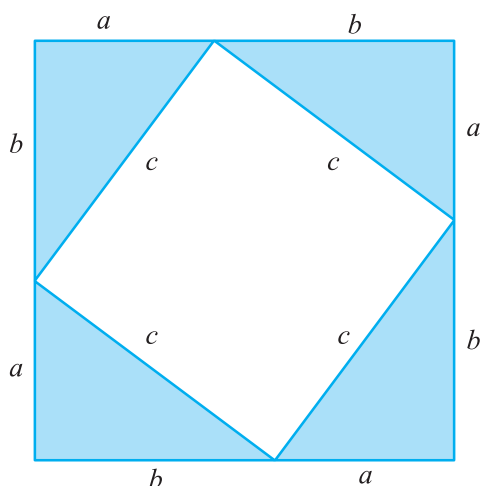

Fig. 3

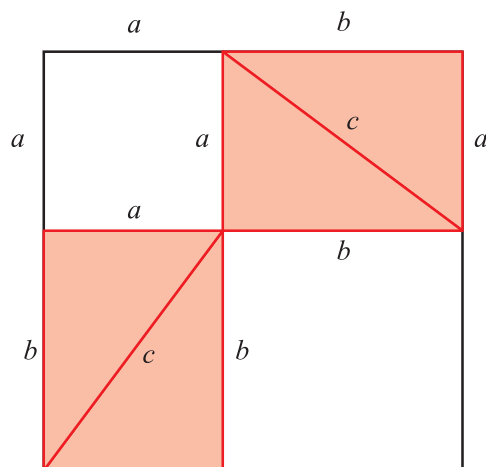

Fig. 4

2. Arrange the other four right triangles (red colour) in the other square as shown in Fig. 4.
3. In Fig. 3, after arranging four right triangles, the part of square of side $a + b$ left is a square of side c .
4. In Fig. 4, after arranging four right triangles, the part of square of side $a + b$ left is made up of two squares one of side a and the other of side b .
5. This shows that $c^2 = a^2 + b^2$.

OBSERVATION

On actual measurement (in centimetres)

1. $a = \underline{\quad}$, $b = \underline{\quad}$, $c = \underline{\quad}$.
2. So, $a^2 = \underline{\quad}$, $b^2 = \underline{\quad}$, $c^2 = \underline{\quad}$.
3. $a^2 + b^2 = \underline{\quad}$.

APPLICATION

1. Whenever two out of three sides of a right triangle are given, the third side can be found by using Pythagoras Theorem.
2. Pythagoras Theorem can be used to solve problems related to ladder and wall, heights and distances etc.

Activity 61

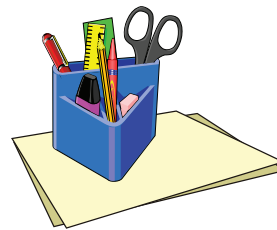

OBJECTIVE

To verify Pythagoras Theorem using a grid paper

MATERIAL REQUIRED

Grid paper, cardboard, pen/pencil, sketch pens of different colours, adhesive, scissors, ruler.

METHOD OF CONSTRUCTION

1. Take a cardboard of convenient size and paste a grid paper on it.
2. Draw a right triangle ABC of sides 3 cm, 4 cm and 5 cm as shown in Fig. 1.

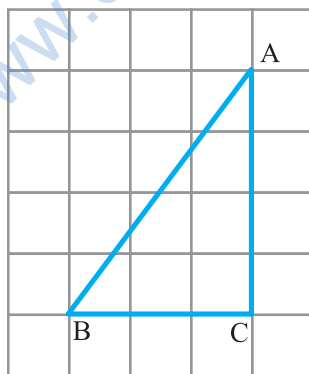

Fig. 1

3. Draw squares on sides AB, BC and CA. Colour square on AC with red and square on BC as blue.
4. Make a cut out of the square on side AC and take out its 16 unit squares in the form of strips each of 4 unit squares.
5. Make a cut out of the square on side BC.

DEMONSTRATION

1. Arrange 16 unit squares (red) along the side of the square on AC as shown in Fig. 2.
2. Place the cut out of square on BC (blue) on the remaining part of the square on side AB as shown in Fig. 2.
3. Square on AB is now completely covered with the 16 unit squares (red) and 9 unit squares (blue).
4. Area of square on AC + Area of square on BC = Area of square on AB.

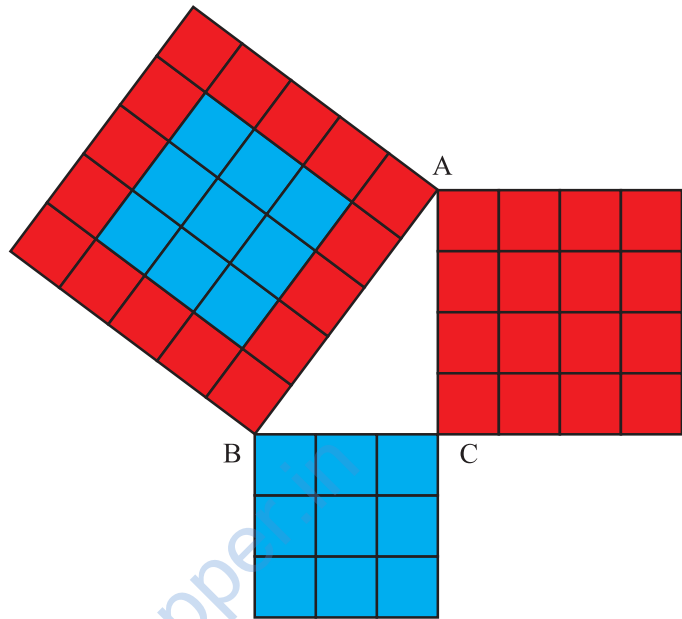

Fig. 2

$$\text{i.e., } AC^2 + BC^2 = AB^2$$

OBSERVATION

Area of square on side AC = ____ square units.

Area of square on side BC = ____ square units.

Area of square on side AB = Area of square on side ____ + Area of square on side ____.

$$AB^2 = AC^2 + ____.$$

APPLICATION

1. Whenever any two sides of a right triangle are given, the third side can be found out using this result.
2. Pythagoras theorem is helpful in studying problems related to right angled triangles such as ladder and window problems.

Activity 62

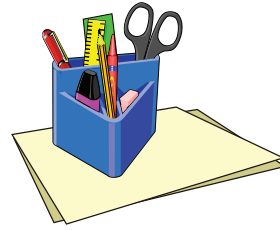

OBJECTIVE

To verify Pythagoras Theorem for an isosceles right triangle

MATERIAL REQUIRED

Cardboard, plain sheets, adhesive, scissors, sketch pens, pencil, tracing paper, geometry box.

METHOD OF CONSTRUCTION

1. Take a piece of cardboard of convenient size and paste a white paper on it.
2. Draw an isosceles right triangle of suitable size on a paper and cut it out. Paste this triangle on the cardboard and name it as ABC (Fig. 1).
3. Draw squares on sides AB, BC and AC (Fig. 1).
4. Make cutouts of these two squares on AB and BC using tracing paper in two different colours say purple and blue.
5. Cut each of these squares along one of the diagonals and obtain 4 right triangles.

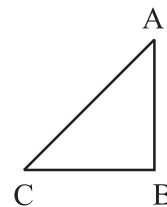

Fig. 1

DEMONSTRATION

1. Arrange the cut out triangles in the square on side AC of the triangle as shown in Fig. 2.
2. Four cut out triangles exactly cover the square on side AC of the triangle.

- Square on side AC is made up of two isosceles purple triangles and two isosceles blue triangles.
- Square on side AC = Square on side BC + Square on side AB
or $AC^2 = BC^2 + AB^2$.

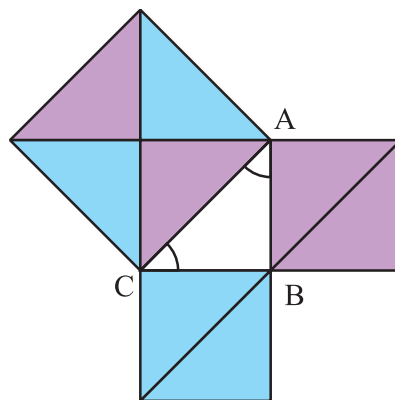

Fig. 2

OBSERVATION

On actual measurement (in centimetres)

- $AB = \underline{\hspace{2cm}}$, $BC = \underline{\hspace{2cm}}$.
 $CA = \underline{\hspace{2cm}}$
so, $AB^2 = \underline{\hspace{2cm}}$, $BC^2 = \underline{\hspace{2cm}}$.
 $CA^2 = \underline{\hspace{2cm}}$.
 $AB^2 + BC^2 = \underline{\hspace{2cm}}$.

APPLICATIONS

- Whenever two, out of three sides of a right triangle are given, the third side can be found out by using Pythagoras Theorem.
- Pythagoras Theorem can be used to solve problems related to ladder and wall, heights and distances etc.

NOTE

This Activity can also be performed by using $45^\circ - 45^\circ - 90^\circ$ set squares.



Activity 63

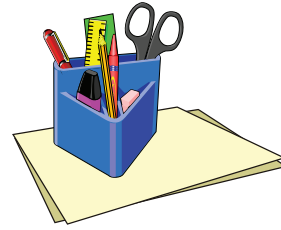

OBJECTIVE

To verify Pythagoras Theorem for a right triangle with one angle 30°

MATERIAL REQUIRED

Cardboard, plain sheets of paper, adhesive, scissors, sketch pens, pencil, tracing paper, geometry box.

METHOD OF CONSTRUCTION

1. Take a piece of cardboard of convenient size and paste a white paper on it.
2. Draw a right triangle with one angle 30° of a suitable size on a paper and cut it out. Paste this triangle on the cardboard and name it as ABC.
3. Draw squares on sides AB, BC and AC of the triangle as shown in Fig. 1.

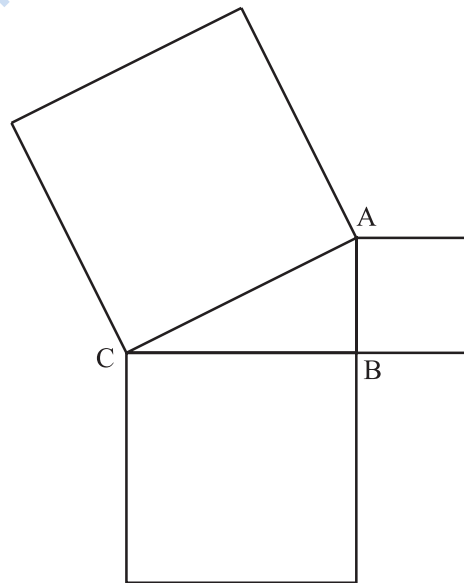
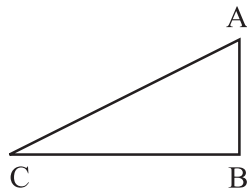

Fig. 1

4. Make cutouts of the squares on sides AB and BC. Divide the cut out of the square on BC into 4 identical right triangles by paper folding/cutting as shown in Fig. 2.

DEMONSTRATION

1. Arrange these 4 triangles and the square on side AB in the square on side AC as shown in Fig. 2.
2. Four cut out triangles and the square on side AB exactly covers the square on side AC of triangle ABC.
3. Square on side AC is made up of four identical right triangles and the square on side AB.
4. Square on side AC = Square on side BC + Square on side AB.

$$\text{or } AC^2 = BC^2 + AB^2.$$

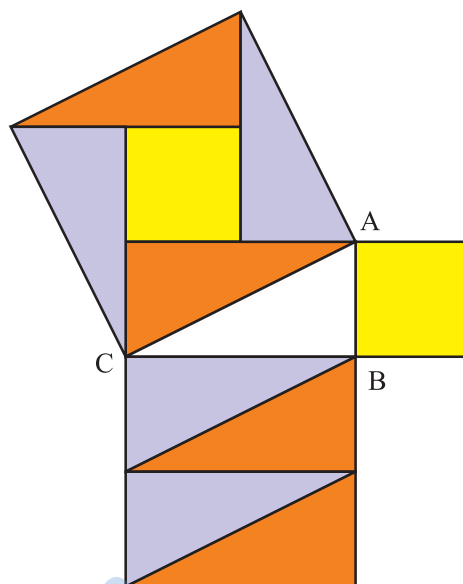

Fig. 2

OBSERVATION

1. On actual measurement (in centimetres)
 $AB = \underline{\hspace{1cm}}$, $BC = \underline{\hspace{1cm}}$, $CA = \underline{\hspace{1cm}}$.
2. $AB^2 = \underline{\hspace{1cm}}$, $BC^2 = \underline{\hspace{1cm}}$, $CA^2 = \underline{\hspace{1cm}}$.
3. $AB^2 + BC^2 = \underline{\hspace{1cm}}$, $CA^2 = \underline{\hspace{1cm}} + \underline{\hspace{1cm}}$.
4. $AB^2 + BC^2 = \underline{\hspace{1cm}}$.

APPLICATION

1. Whenever two out of three sides of a right triangle are given, the third side can be found by using Pythagoras Theorem.
2. Pythagoras Theorem can be used to solve problems related to ladder and wall, heights and distances etc.

NOTE

This activity can also be performed by using $30^\circ - 60^\circ - 90^\circ$ set squares and the square on the smallest side of the set square.

Activity 64

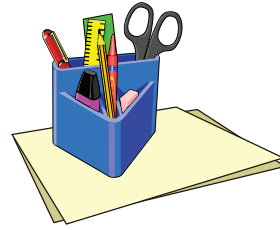

OBJECTIVE

To verify that if two parallel lines are intersected by a transversal, then

- the pairs of corresponding angles are equal.
- the pairs of alternate interior angles are equal.
- the pairs of interior angles on the same side of the transversal are supplementary.

MATERIAL REQUIRED

Drawing board, drawing pins, wires/thread, broomsticks, pen, adhesive, chart paper/glaze paper.

METHOD OF CONSTRUCTION

- Take a drawing board paste a white chart paper on it.
- With the help of a ruler draw two parallel lines AB and CD on the board as shown in Fig. 1.
- Draw a transversal EF intersecting the two lines AB and CD.
- Mark the angles so formed as $\angle 1$, $\angle 2$, $\angle 3$, $\angle 4$, $\angle 5$, $\angle 6$, $\angle 7$ and $\angle 8$. (see Fig. 2).
- Make cutouts of these angles.



Fig. 1

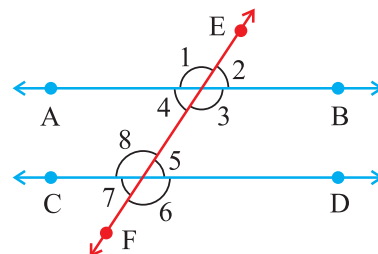
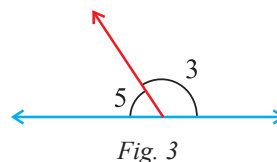

Fig. 2

DEMONSTRATION

- Place the cut out of $\angle 1$ on $\angle 8$ and see whether $\angle 1 = \angle 8$. Now place cut out of $\angle 2$ on $\angle 5$ and see whether $\angle 2 = \angle 5$. Similarly, check the equality of $\angle 3$ and $\angle 6$, $\angle 4$ and $\angle 7$. These pairs of angles are corresponding angles.
- Take the cut out of $\angle 4$ and place it on $\angle 5$ and see whether $\angle 4 = \angle 5$. Similarly, check that $\angle 3 = \angle 8$. These pairs are alternate interior angles.
- Place the cut out of $\angle 3$ and $\angle 5$ adjacent to each other as shown in Fig. 3.
- With the help of a ruler, check that their non common arms are in the same line and hence supplementary. Similarly, check for $\angle 4$ and $\angle 8$. These are pairs of interior angles on the same side of the transversal.



OBSERVATIONS

S. No.	Angles	Type	Are they Equal/ supplementary	Inference
1.	$\angle 1$ and $\angle 8$	Corresponding angles	Equal	Corresponding angles are equal
	$\angle 4$ and $\angle 7$		—	
	$\angle 2$ and $\angle 5$		—	
	$\angle 3$ and $\angle 6$		—	
2.	$\angle 4$ and $\angle 5$	—	—	
	$\angle 3$ and $\angle 8$	—	—	
3.	$\angle 4$ and $\angle 8$	—	—	
	$\angle 3$ and $\angle 5$	—	—	

APPLICATION

- This activity may be used to verify that the pairs of vertically opposite angles are equal.
- The results are useful in solving a number of geometrical problems.

Activity 65

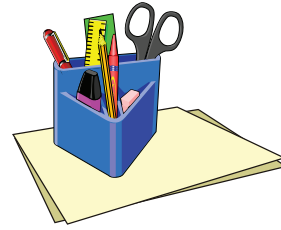

OBJECTIVE

To verify that the sum of three angles of a triangle is 180°

MATERIAL REQUIRED

Coloured paper/drawing sheet, colours, adhesive, scissors, cardboard.

METHOD OF CONSTRUCTION

1. Take a cardboard of convenient size and paste a coloured paper/drawing sheet on it.
2. Cut out two identical triangles using paper.
3. Colour the angles as shown in Fig. 1.
4. Cut out the three angles of one triangle as shown (Fig. 2).

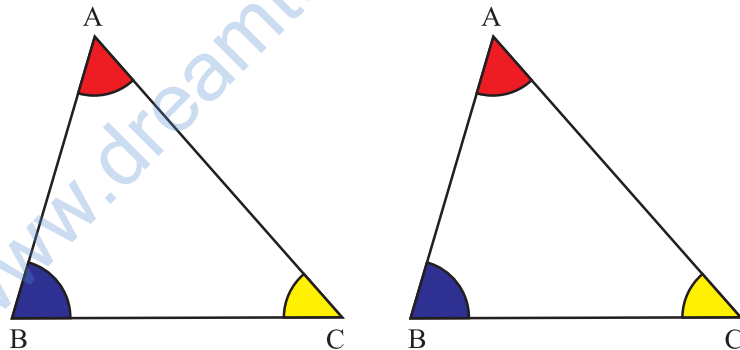

Fig. 1

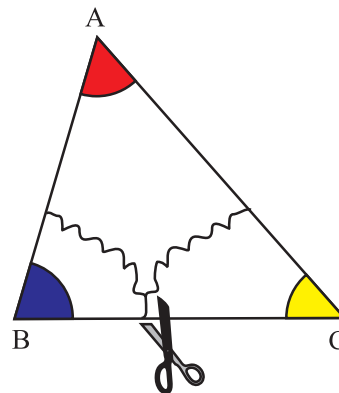

Fig. 2

5. Now paste the three cutouts adjacent to each other with their vertices at a common point P on the cardboard (Fig. 3).

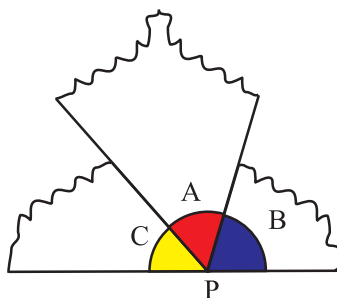

Fig. 3

DEMONSTRATION

The cutouts of the three angles A, B and C placed adjacent to each other at a point P have the arms of angles of $\angle A$ and $\angle C$ as opposite rays and hence form a straight angle.

Therefore, angles A, B and C form a straight angle.

Therefore $\angle A + \angle B + \angle C = 180^\circ$.

OBSERVATION

Measure of $\angle A =$ _____,

Measure of $\angle B =$ _____,

Measure of $\angle C =$ _____,

$\angle A + \angle B + \angle C =$ _____.

Thus, sum of three angles of a triangle is _____.

APPLICATION

This result is used in a number of geometrical problems such as to find the sum of angles of a polygon such as quadrilateral, pentagon etc.

Activity 66

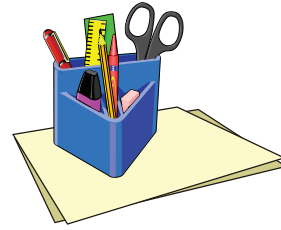

OBJECTIVE

To obtain formula for the area of a parallelogram

MATERIAL REQUIRED

Coloured paper, adhesive, scissors, drawing sheet, pen/pencil.

METHOD OF CONSTRUCTION

1. Take a coloured paper and make a parallelogram through paper folding or draw a parallelogram on a paper.
2. Name the parallelogram as ABCD and cut it out. Paste it on a drawing sheet. Through D make $DE \perp AB$ by paper folding (Fig. 1).
3. Cut out $\triangle ADE$ and paste it along the other side of the parallelogram such that DA is adjacent to CB as shown in Fig. 2.

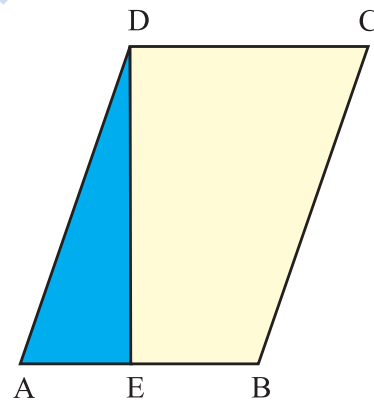

Fig. 1

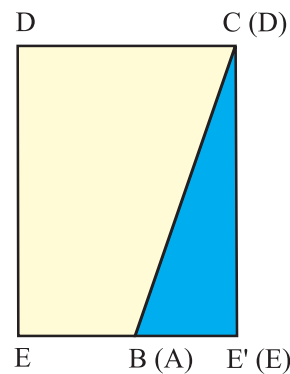

Fig. 2

DEMONSTRATION

1. The breadth of rectangle $DEE'C$ is the height of parallelogram ABCD.
2. Length of rectangle $DEE'C$ is the base of parallelogram ABCD.

3. Area of parallelogram ABCD = area of rectangle DEE'C
= Length \times Breadth
= Base of parallelogram \times Height of parallelogram
= $b \times h$.

OBSERVATION

On actual measurement.

Length of the rectangle = _____,

Breadth of the rectangle = _____,

Area of the rectangle = _____,

Area of parallelogram = Area of rectangle = _____ \times _____.

APPLICATION

The result is used for explaining the formula for Area of a triangle.

www.dreamtopper.in



Activity 67

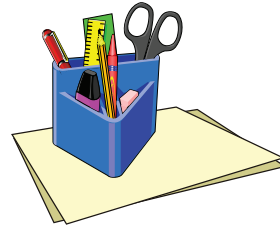

OBJECTIVE

To make a rhombus by paper folding and cutting

MATERIAL REQUIRED

Cardboard, pen/pencil, coloured paper, scissor and adhesive.

METHOD OF CONSTRUCTION

1. Take a rectangular sheet of coloured paper and fold it such that one part exactly covers the other part as shown in Fig. 1.

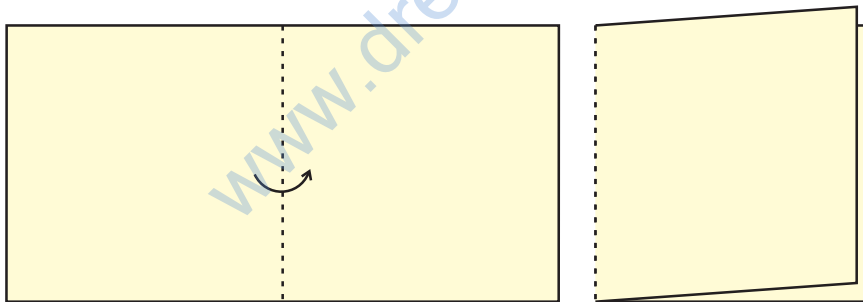

Fig. 1

2. Fold it again as shown in Fig. 2.

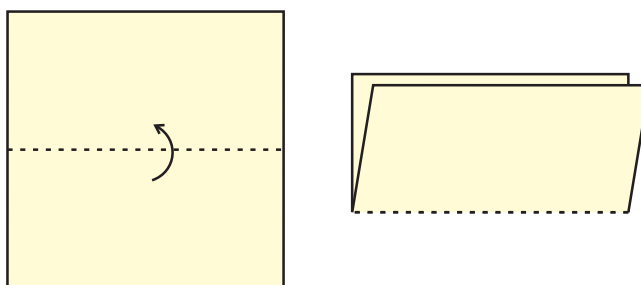

Fig. 2

3. Fold it again as shown in Fig. 3.

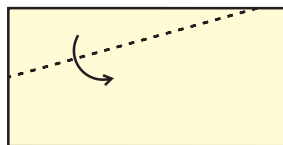

Fig. 3

4. Unfold the sheet and mark the crease with pencil as shown in Fig. 4.

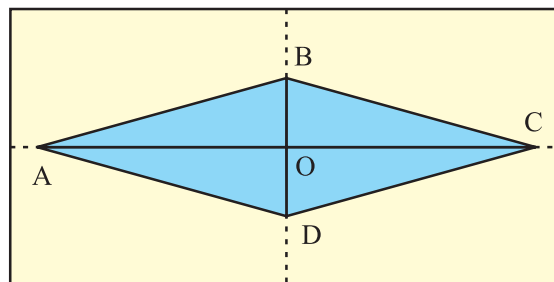

Fig. 4

5. Now cut out the figure ABCD and paste it on a cardboard.

DEMONSTRATION

1. $AB = BC = CD = DA$ as they have been obtained by paper folding.
2. $\angle AOD = \angle COD = 90^\circ$, so, $AC \perp BD$.

Thus figure ABCD is a rhombus.

OBSERVATION

On actual measurement:

$$OC = \underline{\quad}, \quad OA = \underline{\quad},$$

$$OD = \underline{\quad}, \quad OB = \underline{\quad},$$

$$\angle DOC = \underline{\quad}, \quad \angle DOA = \underline{\quad},$$

$$\angle BOC = \underline{\quad}, \quad \angle BOA = \underline{\quad},$$

$$AB = \underline{\quad}, \quad BC = \underline{\quad},$$

$$CD = \underline{\quad}, \quad DA = \underline{\quad},$$

AC and DB are _____ bisector of each other.

ABCD is a _____.

APPLICATION

This activity can be used in understanding the shape of a rhombus and also to explain its properties.

Activity 68

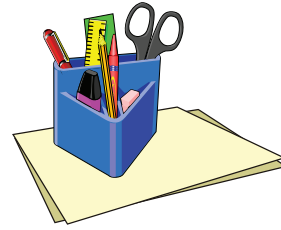

OBJECTIVE

To make a rectangle by paper folding

MATERIAL REQUIRED

Cardboard, coloured paper, pencil/pen, adhesive.

METHOD OF CONSTRUCTION

1. Take a sheet and fold it to get a crease. Name the crease as AB as shown in Fig. 1.

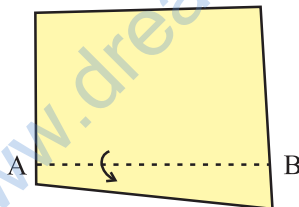

Fig. 1

2. Make CD perpendicular to AB by paper folding as shown in Fig. 2.

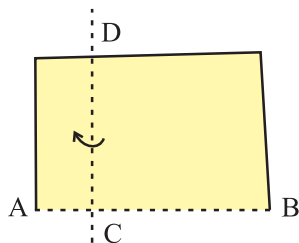

Fig. 2

3. Make $EF \perp CD$ by paper folding (see Fig. 3).

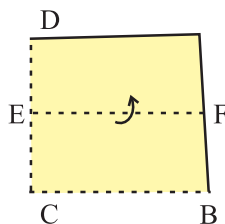

Fig. 3

4. Make $GH \perp EF$ by paper folding (see Fig. 4).

5. Take the cut out of the shape ECHG and paste it on a cardboard.

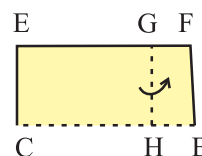

Fig. 4

DEMONSTRATION

1. $CH \perp EC$ as $AB \perp CD$
2. $EG \perp CE$ as $EF \perp CD$
3. $GH \perp EG$ as $GH \perp EF$
4. So, ECHG is a rectangle.

OBSERVATION

On actual measurement:

$$EG = \underline{\quad\quad} ; \quad CH = \underline{\quad\quad}.$$

$$EC = \underline{\quad\quad} ; \quad GH = \underline{\quad\quad}.$$

$$\angle ECH = \underline{\quad\quad}, \quad \angle CHG = \underline{\quad\quad}, \quad \angle HGE = \underline{\quad\quad}, \quad \angle GEC = \underline{\quad\quad},$$

So, ECHG is a .

APPLICATION

The activity may be used to understand the properties of a rectangle.

NOTE

Similar activity can be done to make a square.

Activity 69

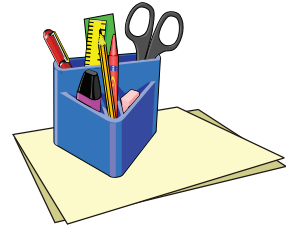

OBJECTIVE

To make a square by paper folding

MATERIAL REQUIRED

Cardboard, thick paper/pen, pencil, adhesive.

METHOD OF CONSTRUCTION

1. Take a sheet of thick paper. Fold it as shown in Fig. 1.

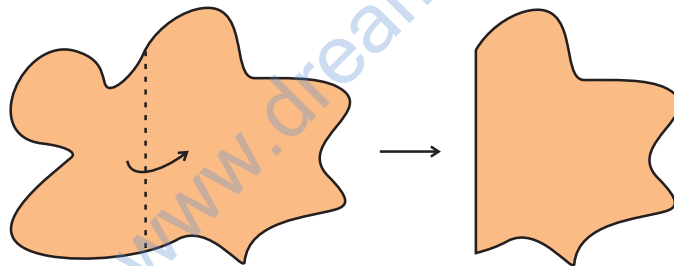

Fig. 1

2. Fold it again as shown in Fig. 2.

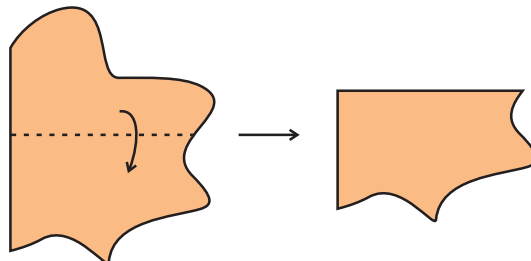

Fig. 2

- Fold it again as in Fig. 3.

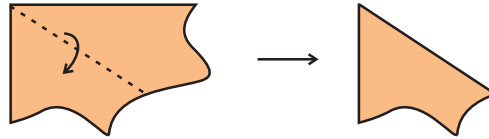

Fig. 3

- Fold it again as in Fig. 4.

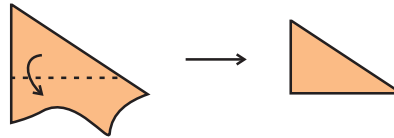

Fig. 4

- Unfold and mark the crease as in Fig. 5.
- Name the square as ABCD and point of intersection of diagonal AC and BD as O.
- Cut out shape ABCD and paste it on a card board.

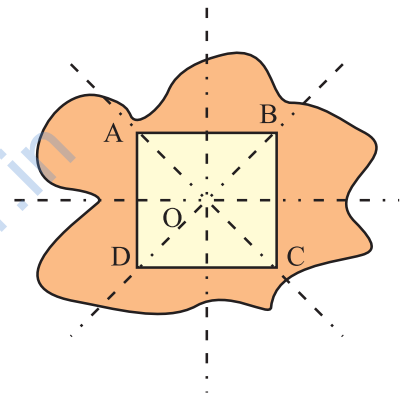

Fig. 5

DEMONSTRATION

- From Fig. 5 $DO = OB = OC = OA$.
- $DB = AC$.
- $AB = BC = CD = DA$.
- ABCD is a square.

OBSERVATION

On actual measurement

$$DB = \underline{\quad} ; \quad AC = \underline{\quad}.$$

$$AB = \underline{\quad} ; \quad BC = \underline{\quad}.$$

$$DC = \underline{\quad} ; \quad AD = \underline{\quad}.$$

ABCD is a $\underline{\quad}$.

APPLICATION

This activity may be used to understand the properties of a square.

Activity 70

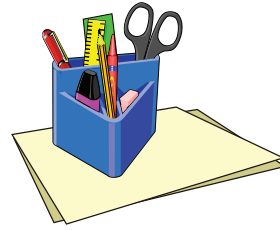

OBJECTIVE

To obtain a parallelogram by paper folding

MATERIAL REQUIRED

Rectangular sheet of paper, coloured pen.

METHOD OF CONSTRUCTION

1. Take a rectangular sheet of paper.
2. Fold it parallel to its breadth at a convenient distance and make a crease (1) as shown in Fig. 1.

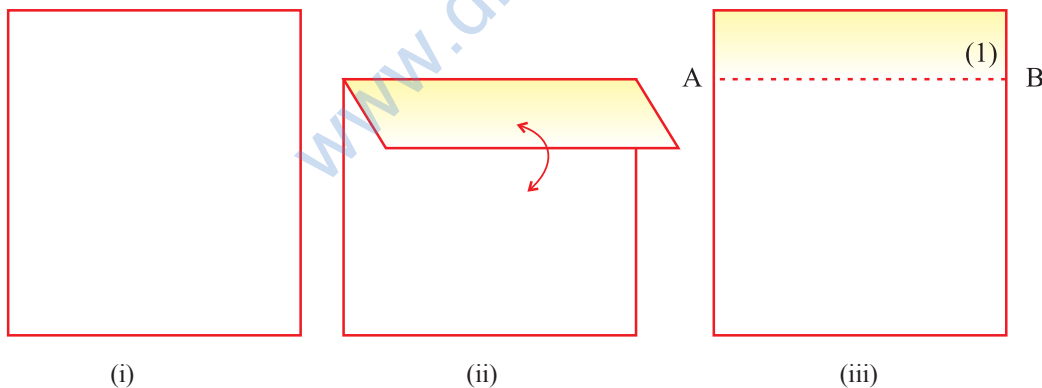

Fig. 1

3. Obtain a crease perpendicular to crease (1) at any point on it to get a crease (2) as shown in Fig. 2. Call it as CD.

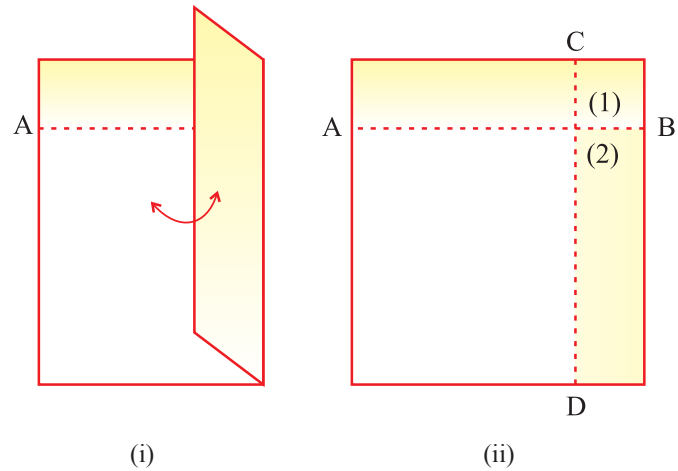

Fig. 2

- Obtain a third crease perpendicular to crease (2) at any point on crease (2) and call it as crease (3) as shown in Fig. 3. Call it as EF.

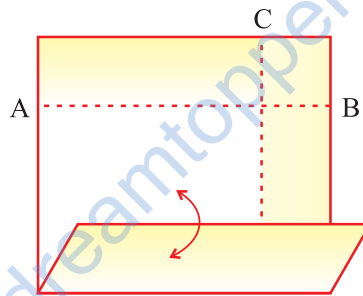

Fig. 3

- Mark crease (1) and (3) with pen as shown in Fig. 4.

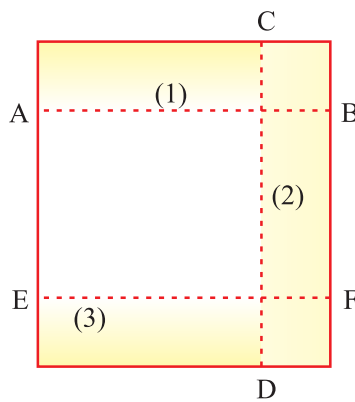

Fig. 4

6. Make a fold, cutting the creases (1) and (3) as shown in Fig. 5. Call it crease (4).

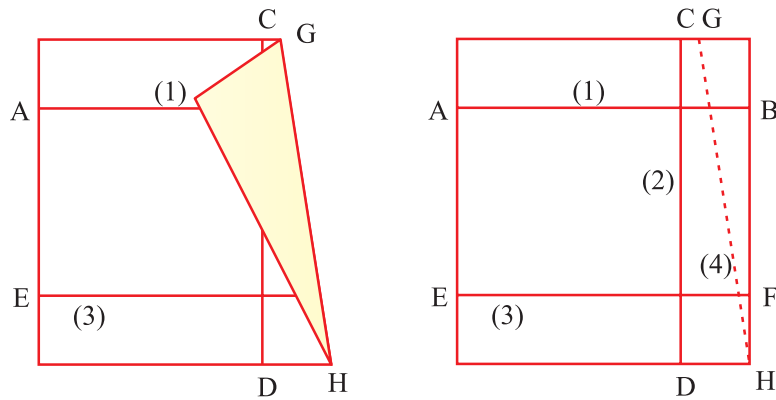

Fig. 5

7. Adopting the method used for getting a pair of parallel lines as explained in Steps 2 to 5, get a fold parallel to crease (4), call this as crease (5) as shown in Fig. 6.

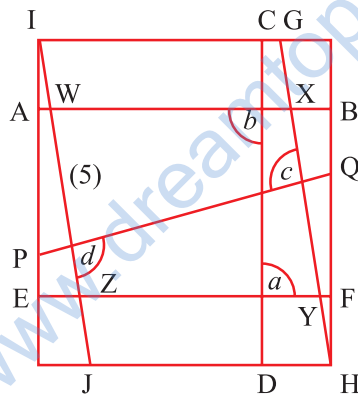

Fig. 6

DEMONSTRATION

In Fig 6, $CD \perp AB$

$EF \perp CD$

Therefore,

$AB \parallel EF$

$$PQ \perp GH$$

$$IJ \perp PQ$$

Therefore,

$$GH \parallel IJ$$

Thus, WXYZ is a parallelogram.

OBSERVATION

$$\angle a = \underline{\hspace{2cm}}$$

Therefore, $CD \perp \underline{\hspace{2cm}}$.

$$\angle b = \underline{\hspace{2cm}}$$

Therefore, $EF \perp \underline{\hspace{2cm}}$.

Thus,

$$AB \underline{\hspace{2cm}} EF$$

$$\angle c = \underline{\hspace{2cm}}$$

Therefore, $PQ \perp \underline{\hspace{2cm}}$.

$$\angle d = \underline{\hspace{2cm}}$$

Therefore, $IJ \perp \underline{\hspace{2cm}}$.

Thus

$$GH \underline{\hspace{2cm}} IJ$$

This shows that WXYZ is a $\underline{\hspace{2cm}}$.

APPLICATION

Construction of a rectangle can also be done using this activity.



Activity 71

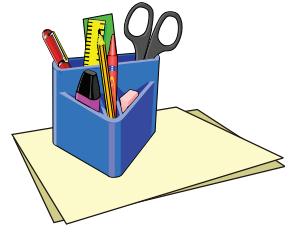

OBJECTIVE

To draw regular polygons, using circles

MATERIAL REQUIRED

Coloured paper, scissors, geometry box.

METHOD OF CONSTRUCTION

1. Draw three circles of the same radii on a coloured paper.
2. Take one of the circles and draw three angles each of $120^\circ (= \frac{360^\circ}{3})$ at the centre as shown in Fig. 1.
3. Take second circle and draw four angles each of $90^\circ (= \frac{360^\circ}{4})$ at the centre as shown in Fig. 2.
4. On the third circle, draw five angles each of $72^\circ (= \frac{360^\circ}{5})$ at the centre as shown in Fig. 3.

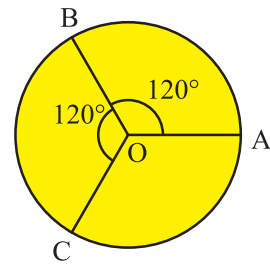

Fig. 1

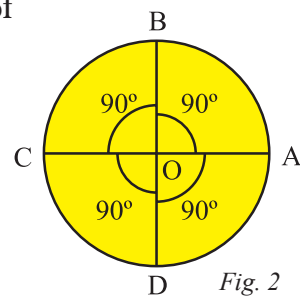

Fig. 2

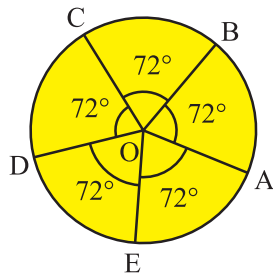

Fig. 3

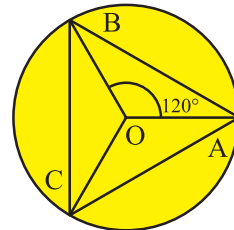

Fig. 4

DEMONSTRATION

1. In Fig. 1, join AB, BC and CA as shown in Fig. 4. ABC is a regular polygon of sides three (an equilateral triangle).
2. In Fig. 2, join AB, BC, CD and DA as shown in Fig. 5. ABCD is a regular polygon of sides four (a square).
3. In Fig. 3, join AB, BC, CD, DE and EA as shown in Fig. 6.

ABCD is a regular polygon of sides five.

Similarly, regular polygons of sides six, eight, nine and ten sides can be drawn.

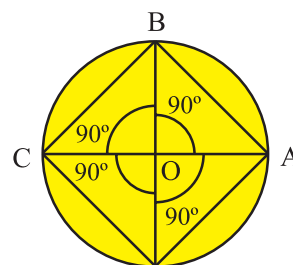

Fig. 5 D

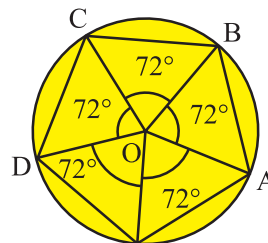

Fig. 6 E

OBSERVATION

On actual measurement:

S. No.	Name of sides	Length of sides (cm)
Figure 4	Equilateral Δ	—
	AB = ____, $\angle A =$ ____.	—
	BC = ____, $\angle B =$ ____.	—
	AC = ____, $\angle C =$ ____.	—
Figure 5	AB = ____, $\angle A =$ ____.	—
	BC = ____, $\angle B =$ ____.	—
	CD = ____, $\angle C =$ ____.	—
	AD = ____, $\angle D =$ ____.	—
Figure 6	AB = ____, $\angle A =$ ____.	—
	BC = ____, $\angle B =$ ____.	—
	CD = ____, $\angle C =$ ____.	—
	DE = ____, $\angle D =$ ____.	—
	AE = ____, $\angle E =$ ____.	—

In Fig. 4 all the three sides are ____ and all the three angles are ____.
So, ABC is a regular polygon of sides ____.

In Fig. 5, all the four sides are _____ and all the four angles are _____.

So, ABCD is a regular polygon of sides _____.

In Fig. 6, all the five sides are _____ and all the five angles are _____.

So, ABCDE is a polygon of sides _____.

APPLICATION

This activity is useful in explaining the meaning of a regular polygon and how to draw a regular polygon.

www.dreamtopper.in



Activity 72

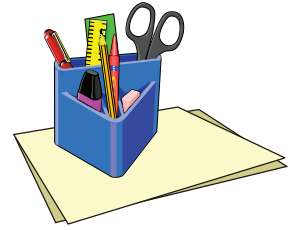

OBJECTIVE

To make a kite by paper folding and cutting

MATERIAL REQUIRED

Thick paper, cardboard, pen/pencil, ruler, scissors, adhesive.

METHOD OF CONSTRUCTION

1. Take a rectangular thick white paper.
2. Fold it once as shown in Fig. 1.

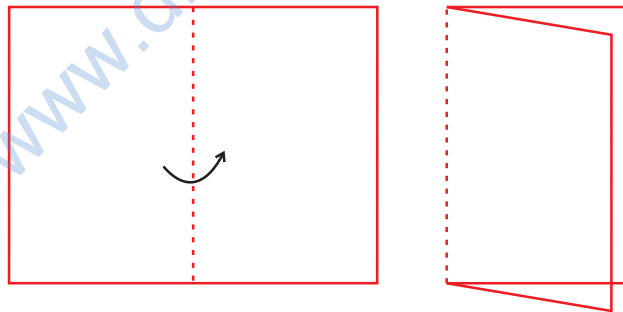

Fig. 1

3. Draw two line segments of different lengths as shown in Fig. 2.

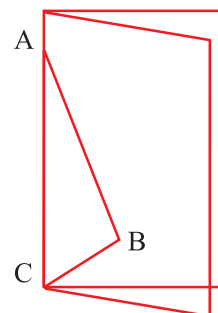
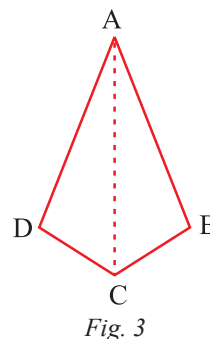

Fig. 2

4. Cut along AB and BC and unfold it to get a figure as shown in Fig. 3. Paste the cut out on a cardboard.



DEMONSTRATION

1. AB is equal to AD as AB covers AD exactly in Fig. 2.
2. BC is equal to DC as BC covers DC exactly in Fig. 2.
3. So, ABCD is a kite.

OBSERVATION

On actual measurement:

$$AB = \underline{\quad}. \quad AD = \underline{\quad}.$$

$$BC = \underline{\quad}. \quad DC = \underline{\quad}.$$

$$\text{Measure of } \angle DAC = \underline{\quad}.$$

$$\angle BAC = \underline{\quad}.$$

$$\angle DCA = \underline{\quad}, \quad \angle BCA = \underline{\quad}.$$

$$\angle DAC = \angle \underline{\quad}.$$

$$\angle DCA = \angle \underline{\quad}.$$

So, ABCD is a .

APPLICATION

This activity will help in understanding the shape of a kite and all its properties.

Activity 73

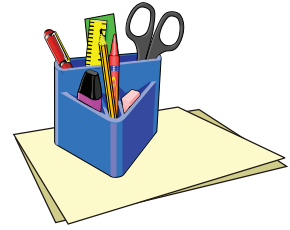

OBJECTIVE

To verify that the sum of four angles of a quadrilateral is 360°

MATERIAL REQUIRED

Cardboard, coloured glaze paper, colours, ruler, pencil, drawing sheet, scissors, tracing paper.

METHOD OF CONSTRUCTION

1. Take a cardboard of convenient size and cover it with a light coloured glaze paper.
2. Take a drawing sheet and draw a quadrilateral on it.
3. Cut it out and paste it on the cardboard. Name it as ABCD (Fig. 1).

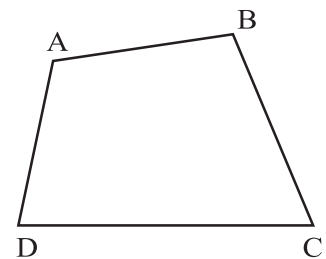

Fig. 1

Make a trace copy of the quadrilateral ABCD.

4. Colour the four angles with different colours in both the quadrilaterals (Fig. 2).

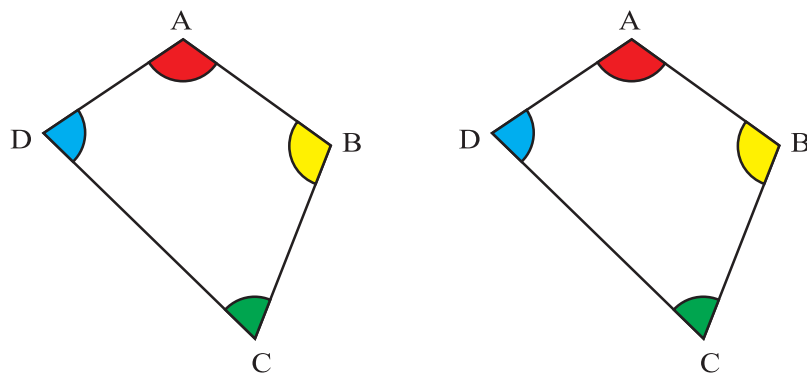

Fig. 2

5. Cut out the angles A, B, C and D from the trace copy and arrange them on the cardboard at a point P so that there is no gap between adjacent angles as shown in Fig. 3.

DEMONSTRATION

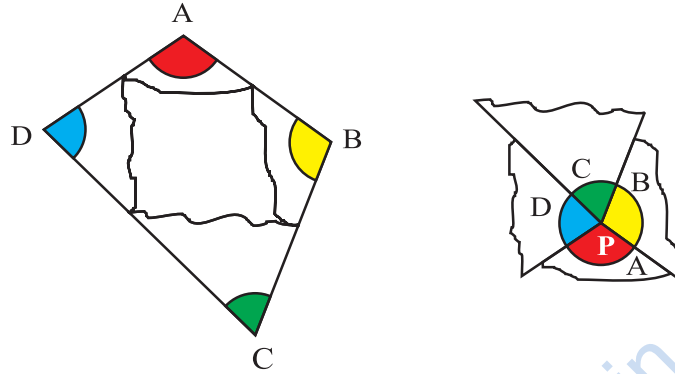

Fig. 3

1. The four angles A, B, C and D make a complete angle at the point P.
2. Sum of angles at point P is 360° .

So, $\angle A + \angle B + \angle C + \angle D = 360^\circ$.

OBSERVATION

On actual measurement:

Angle	Measure
$\angle A$	_____
$\angle B$	_____
$\angle C$	_____
$\angle D$	_____
$\angle A + \angle B + \angle C + \angle D$	_____

APPLICATION

This activity can be used in solving many geometrical problems.

Activity 74

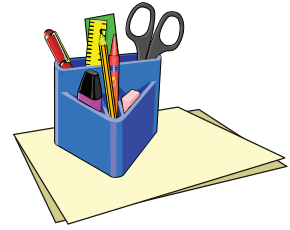

OBJECTIVE

To verify that sum of exterior angles of a triangle and quadrilateral taken in order is 360° or four right angles

MATERIAL REQUIRED

Cardboard, white drawing sheet, colours, pencil, ruler, scissors, tracing paper.

METHOD OF CONSTRUCTION

(A) Triangle

1. Take a cardboard of convenient size and paste a coloured glaze paper on it.
2. Draw a triangle ABC on a drawing sheet and produce its sides in an order as shown in Fig. 1.

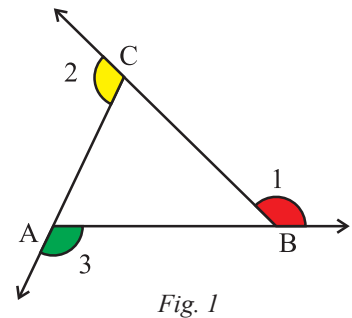

3. Name the exterior angles as 1, 2 and 3 and colour them as shown above in Fig. 1.
4. Make a trace copy of the above figure and colour the exterior angles with the same colours as in Fig. 1.
5. Cut out the exterior angles neatly.

(B) Quadrilateral

1. Draw a quadrilateral ABCD on a drawing sheet and produce its sides in an order as shown in Fig. 2.

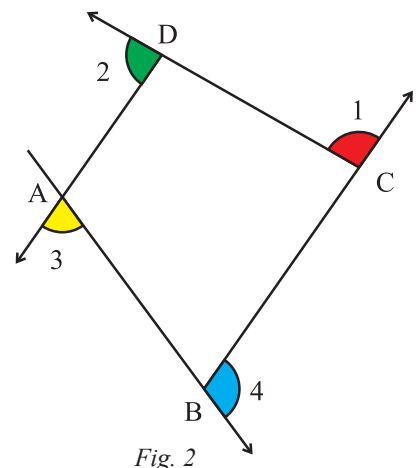

- Name the exterior angles as 1, 2, 3 and 4 and colour them as shown in Fig. 2.
- Make the trace copy of the above figure and colour the exterior angles with the same colours as in Fig. 2.
- Cut out the exterior angles neatly.

DEMONSTRATION

(A)

- Place the cutouts of the exterior angles of Fig. 1 adjacent to each other at a point P without having any gap between any two consecutive angles as shown in Fig. 3.

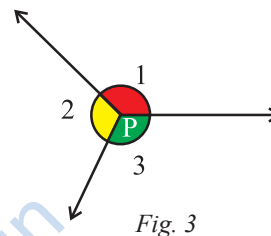

(B)

- Place the cutouts of the exterior angles of Fig. 2 adjacent to each other at a point Q without having any gap between any two consecutive angles as shown in Fig. 4.
- The exterior angles in Fig. 3 as well as in Fig. 4 make a complete angle at the points P and Q respectively.
- The sum of angles at a point is 360° .

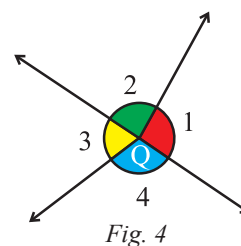

So, $\angle 1 + \angle 2 + \angle 3 = 360^\circ$. for (A)

and $\angle 1 + \angle 2 + \angle 3 + \angle 4 = 360^\circ$ for (B)

OBSERVATION

On actual measurement:

(A) Triangle

Angle	Measure
$\angle 1$	—
$\angle 2$	—
$\angle 3$	—
$\angle 1 + \angle 2 + \angle 3 =$	—.

(B) Quadrilateral

Angle	Measure
$\angle 1$	—
$\angle 2$	—
$\angle 3$	—
$\angle 4$	—
$\angle 1 + \angle 2 + \angle 3 + \angle 4 =$	—.

APPLICATION

This activity can be used to find the sum of exterior angles produced in order, of a pentagon, a hexagon or in general any polygon.

www.dreamtopper.in

