

2.0 Module 2

Fundamentals of 2D:

18 hours (12 in school and 6 at home) = 18 credits



Exposure 1
Exposure 2
Exposure 3
Exposure 4

- Elements of Design and Expressions
- Principles of Design: Positive-Negative Space + Symmetry
- Structure in Design
- Graphicalisation + Symbols

Overall Task

Exploring Fundamentals of 2D Shapes

2.1 Task (at School + Home)
2.2 Task (at School + Home)
2.3 Task (at School + Home)
2.4 Task (at School + Home)

- Elements of 2D Design and Expressions
- Principles of 2D Design – Symmetry and Negative and Positive Spaces
- Structure and Patterns in 2D Design
- Visual Graphicalisation and developing an Icon

Final Output

- A presentation and exhibition of all the works
- + Reflections, Self Assessment and References

2.0 Module 2

Fundamentals of 2D:

18 hours (12 in school and 6 at home) = 18 credits

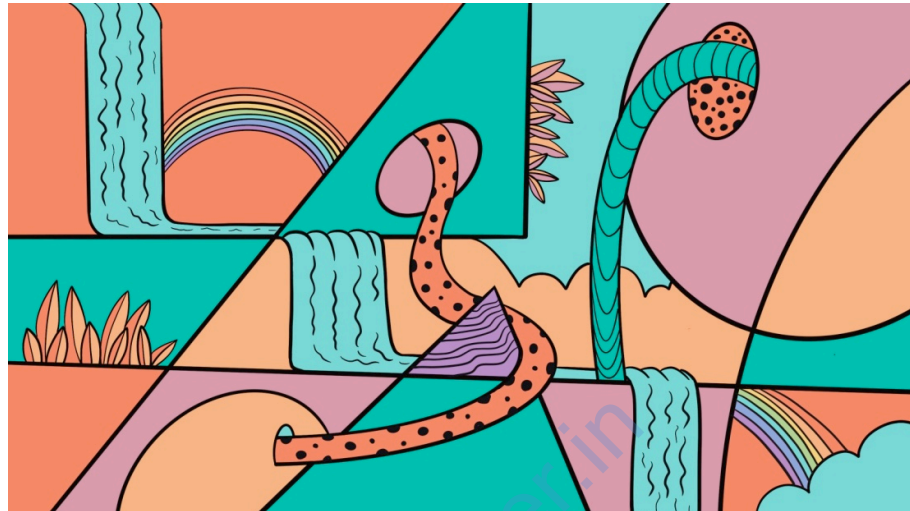

Introduction

Understanding the fundamentals of 2D forms the basis for learning the visual language. This in turn forms the foundation for Communication Design. This module gives an exposure to visual elements points, lines, planes, and volumes and their features colour, shape, texture, position, orientation, and size. You will learn how to apply principles like balance, hierarchy and proportion and be able to create patterns, layouts and applications for communications. The outcome could be in the form of graphics, illustrations, signage, visualization, photography, print and publishing, web design, animation, etc. The learning from the previous module on 'Documentary Photography' on compositions, layout, expressions can be made use of in solving tasks in this module.

Aim of the Course

To expose school students (Grade 9) to fundamentals and principles of 2 dimensional design. It should create an awareness and sensitivity towards compositions in two-dimensional spaces. The students should be able to use basic principles to understand, analyse and create 2D applications.

Place:

Place: Task 2.1, Task 2.2, Task 2.3 and Task 2.4
– done at both school and at home



Grouping:

Grouping: Done as an individual exercise/assignment



Equipment: Sketchbooks for sketching, Stationary (Pencils, Pens, Colours, Tracing paper, Black Ink and brush or brush pen, colour pens), students may use digital devices like computers or tablets (if available, but not necessary)

Exposures

Exposure 1 (prerequisite): Elements of Design - Point, Line, plane, volume, Colour, Position, Orientation, Texture, Basic Shapes

Exposure 2 (before task 2): Positive-Negative space explained with examples

Exposure 3 (before task 3): Principles of Design demonstrated - Balance, Rhythm, Emphasis, Unity, Proportion, etc.

Exposure 4 (before task 4): Structure in design - Symmetry - Asymmetry, Centricity - eccentricity, Golden ratio, Grids, Patterns

Exposure 5 (before task 5): Visual Graphicalisation

Task Sequence: Task 2.1 + Task 2.2 + Task 2.3 + Task 2.4

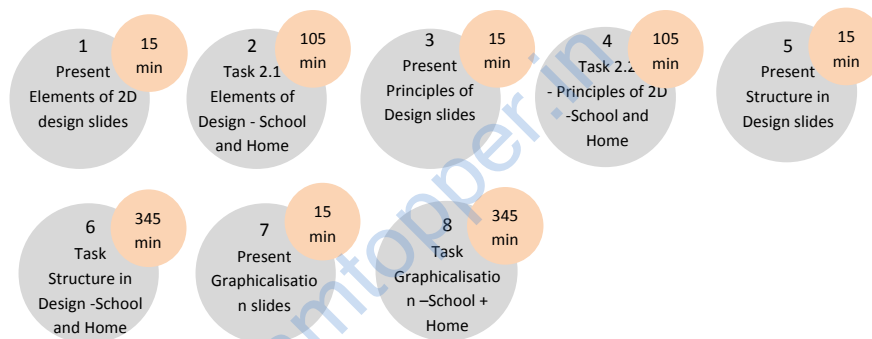

Design Thinking & Innovation Process involvement:

This task involves the following phases of the DT&I Process:

Phase 1. Observe/Empathise/Research (observation of Design Elements)

Phase 2. Understand/Analyse/Define (Fundamentals and Principles)

Phase 3. Ideate/Alternate/Create (trying creative alternatives)

Phase 4. Build/Prototype/Detail (making a presentation)

Phase 5. Evaluate/Reflect/Implement (feedback from others)

Mapping SDG Goals: The following SDG goals need to be considered while solving this task. While documenting elements and expressions, do think of gender equality and reduced inequalities and concern for life on our planet.



Task 2.0

Task 2.0 = 2.1 + 2.2 + 2.3: + 2.4

School Hours: 12, Home hours: 6



Task 2.1:

Done at School + Home



Task 2.1 = 2.1a + 2.1b + 2.1c:

2 hours at School + 1 hours at Home, Done individually

Topic title:

Elements of 2D Design:

The elements of 2D design are points, lines, planes, textures, etc. (2D stands for 2 dimensional).

Here are a few tasks to understand some of these.

Exposure 1 (prerequisite): Elements of Design in 12 slides - Point, Line, plane, volume, Colour, Position, Orientation, Texture, Basic Shapes

Task 2.1a

(done in School)



Task 2.1a

School hours: 1, Done individually

Topic title:

Line and Expressions:

In this task, you'll try to express feelings with the shape of lines.

1. Draw a continuous long and winding black line to fill up the space (4-5 compositions) on an A4 size paper (horizontal format) to express any of the following and
2. Give a name/title for this composition

Examples of different types of lines:

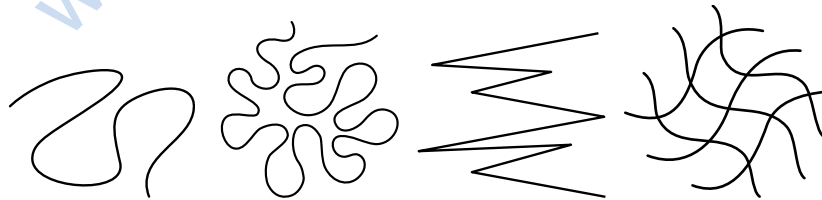

Clue: Try expressing – a line taking a walk, a happy line, an angry line, a cute line, a playful line, a mischievous line, a friendly line, etc.

Output 2.1a: 4 to 5 compositions of lines with different expressions

Task 2.1b

(done in School)



Task 2.1b

School hours: 1, Done individually

Topic title:

Planes and Expressions:

Create expressions with the basic design elements – circles, squares and triangles. Do note that the circle is soft and smooth, a square is rigid and solid and a triangle is active and playful.

You could use multiple numbers of these elements, vary their size, change their orientation and overlap them.

Clue: Try expressing – friendship/togetherness, anger, imbalance, heaviness, conflict, etc.

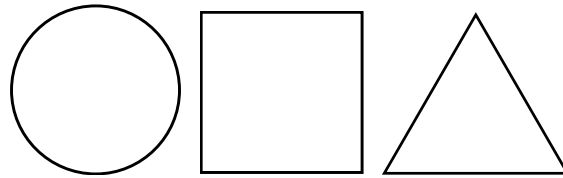

1. Make a composition of the elements to express any emotion or feeling on an A4 size paper (horizontal format)
2. You can make use of coloured paper cut-outs or draw the basic element characters and colour them

Output 2.1a: 4 to 5 compositions of planes with different expressions

Task 2.1c

(done at Home)



Task 2.1c

Home hours: 1, Done individually

Topic title:

Observing Forms with Points:

Observe at home any object that ends up as a point. You could locate points when 3 surfaces meet. You could locate objects that end up with as a point.

1. Note down the list of objects where you can identify points
2. Create a representation of any one of the objects by making tiny dots using a black pen repeatedly such that the form of the object is created.

- The process of doing this task is called Stippling

Example of a cube created with dots:



3. You could use pencil to draw the outline and use the pen to make the dots

Output 2.1c: Draw this on an A4 size sheet in horizontal format

OR

Topic title:

Surfaces with parallel Lines:

Observe at home any object that ends up as a line. You could locate lines when 2 surfaces meet. You could locate objects whose surfaces end up as lines.

1. Note down the list of objects where you can identify lines

1. Draw parallel lines such that there is a small variation each time you draw the line. This change in direction of the line will result in a new visible surface.

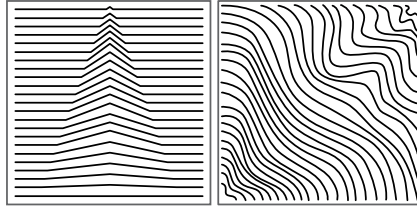

examples

- the lines could be straight or curved or angular.

2. Try out any of the following options: A square, a circle, a wave, a star, a diamond, a face, etc.

Output 2.1c: Make 2-3 compositions on A4 sheets in horizontal format

Task 2.2:

Done at School + Home



Task 2.2 = 2.2a + 2.2b

2 hours at School + 1 hours at Home, Done individually

Topic title:

Principles of Design:

The principles of design include Balance, Negative and Positive spaces, Rhythm, Emphasis, Unity, Proportion, etc. Here are the tasks to understand some of these.

Exposure 3: Principles of Design - Balance, Rhythm, Emphasis, Unity, Proportion, etc.

Task 2.2a:

Done at School



Task 2.2a

School hours: 2, Done individually

Topic title:

Identify Negative Shapes in the Environment:

Draw a Tree or a Plant – but instead of drawing its branches, draw the spaces (shapes) in between the branches.

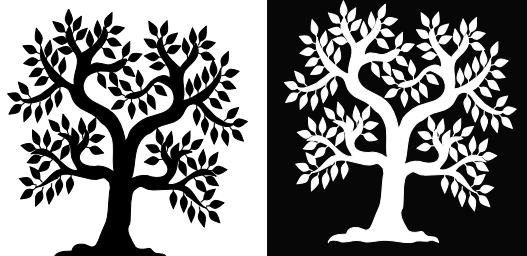

1. Choose a tree to represent

2. Make 2 compositions. In one draw the tree/plant in black colour (positive shape) and in another fill the left out spaces with black (negative shape)

Output 2.2a: Make two compositions on A4 size sheets in horizontal format

Task 2.2b

(done at Home)



Task 2.2b

Home hours: 1, Done individually

Topic title:

Observe Objects and Spaces with Symmetry

Observe at home objects and spaces that are symmetrical. Can you also identify the type of symmetry?

These are the types of symmetry:

Reflection: elements reflected across an axis

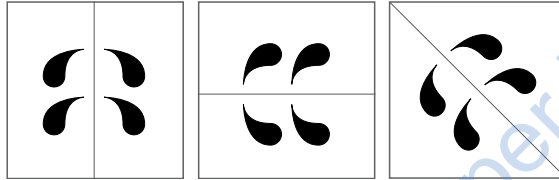

Rotational: elements rotated around a point

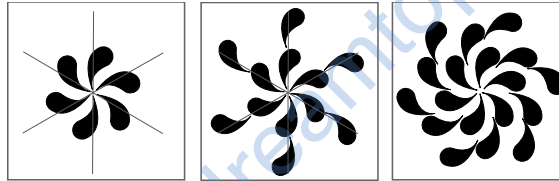

Translational: elements are repeated by shifting or sliding its position

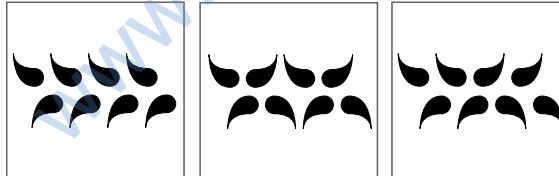

1. Note down the list of 10 objects or spaces in your home surroundings that you can identify the above-mentioned types of symmetry

2. Take an A4 size sheet of paper. Fold it any manner, 3 to 4 times. Take a scissors and make cuts in it (any type of cut). Open the paper and identify the types of symmetry that you have created.

3 Try out 2 to 3 variations.

Output 2.2b: Examples of Symmetry at Home + cut out in paper

Task 2.3:

Done at School + Home



Task 2.3 = 2.3a + 2.3b:

2 hours at School + 1 hours at Home, Done individually

Topic title:

Structure in Design:

The principles of structure in design include the following - Symmetry - Asymmetry, Centricity - eccentricity, Golden ratio, Grids and Patterns

Exposure 4: Rule based design - Symmetry - Asymmetry, Centricity - eccentricity, Golden ratio, Grids

Task 2.3a

(done in School)



Task 2.3a

School Hours: 4, Done individually

Topic title:

Tessellating Patterns:

In this task you'll learn to create tessellations.

- In a tessellation, a shape is repeated again and again such that there is no gaps or overlaps between the repeated shapes. Tessellations are also a form of tiling.
- Triangles, squares, rectangles and hexagons can be repeated to form tessellations. You can also use combinations of them to form tessellations.

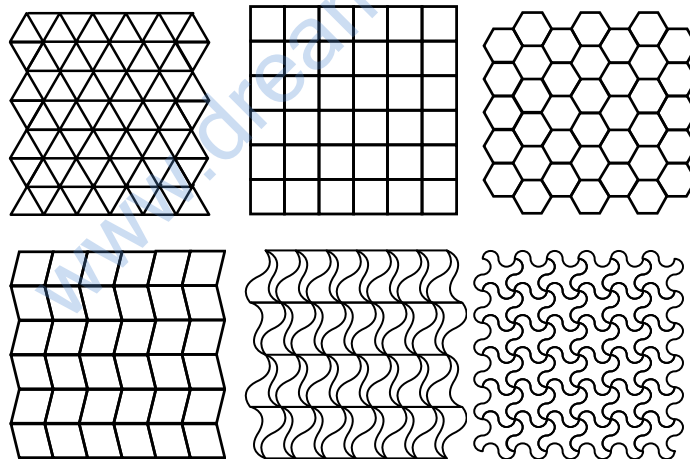

1. Make one tessellation pattern using triangles, squares or rectangles and hexagons
2. Make another tessellation pattern using variations of triangles, squares or rectangles and hexagons something like the patterns shown above in the second row
2. The basic unit can be around 30mm or 3 cm in width
3. After you fill up the sheet, colour them using at least 2 contrasting colours.

Output 2.3a: Draw the two tessellations on A4 size sheet in horizontal format

Task 2.3b

(done at Home)



Task 2.3b

Home Hours: 2, Done individually

Topic title:

Golden Ratio:

The golden ratio rooted in mathematical principles helps one create balanced pleasing proportionate designs.

- the golden ratio is generated by the Fibonacci Sequence, which is a series of numbers created with the addition of previous 2 numbers.

Fibonacci Sequence: 1, 1, 2, 3, 5, 8, 13, 21, 34, etc. If you divide the larger number by its previous number you get the golden ratio = 1.618 which is also called as Phi

- if you draw and place squares with these numbers as its side, and connect the diagonals with a curve, it results in a spiral. This spiral is called as the golden spiral.

- you can notice this spiral in nature – the spiral in sea shells, sunflower seeds, eye of the storm, etc. and designers use the proportion of the golden ratio while creating their designs.

Output 2.3b: Take an A4 sheet of paper and draw a Golden Spiral as shown below.

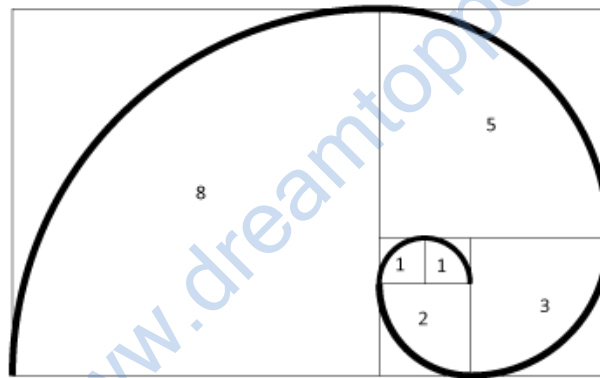

Task 2.4:

Done at School + Home



Task 2.4 = 2.4a + 2.4b:

4 hours at School + 2 hours at Home, Done individually

Topic title:

Visual Studies and Graphicalisation:

In this task, you study a state symbol, which could be a state animal, state bird, state tree or a state flower. You visually explore through sketching its variations from different points of view and then simplify the form and create a graphical visual of the state symbol.

Exposure 4: Visual Graphicalisation and developing an Icon

Task 2.4a

(done at Home)



Task 2.4a

Home Hours: 2, Done individually

Topic title:

Visual Studies:

1. Select a state symbol from any state in India – could be a state animal, state bird, state tree or a state flower.
2. Study the form of the chosen state symbol
3. Sketch variations of it from different angles or view-points (could also be front view, side view, in action, close-ups, etc.)
4. Select 3 of these sketches and draw them as lines

Output 2.4a: 3 variations of the chosen state symbol as sketches in line format on 3 A4 size sheets

Task 2.4b

(done at School)



Task 2.4b

School Hours: 4, Done individually

Topic title:

Designing a Graphical Icon/Symbol:

An Icon or Symbol represents a graphical or visual representation of a concept in a simple easily identifiable manner.

The task is to graphically represent as an Icon the chosen state symbol.

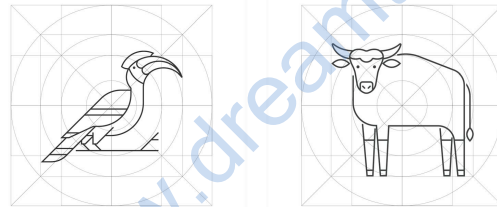

examples

1. You have 3 variations of the chosen state symbol as sketches in line format (from previous task 2.4a)
2. Redraw it to make it simplified (you can make the lines smooth, equal thickness and make it align to an axis) reducing it to its essentials
3. Draw the icons as black coloured thick lines of uniform thickness (3 to 5mm)

Output 2.4b: 3 variations of the chosen state symbol as icons in line format on 3 A4 size sheets

Task 2.4 References:

Graphicalisation Example References:

Indian Elephant:

<https://www.dsource.in/case-study/2d-form-exploration-elephant>

Peacock:

<https://www.dsource.in/case-study/2d-form-exploration-peacock>

Swan:

<https://www.dsource.in/case-study/2d-form-exploration-swan>

Reflection:



Questions to ponder:

- Can you discover elements and principles of design in nature and built the environment surrounding you?
- Would you like to arrange objects around your house based on the principles of design?
- Based on the principles of Visual Graphicalization, can you create a symbol for one of your activities?

Self-Assessment:

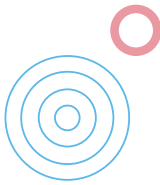

Assessment Criteria (Task 2.1a + 2.1b + 2.1c) – Assess yourself:

Elements of 2D Design:

- The task of capturing ‘Expressions’ with the shape of ‘Lines’ was done well. (Individual Assessment, Task 2.1a)

<input type="checkbox"/>	<input type="checkbox"/>	<input type="checkbox"/>	<input type="checkbox"/>	<input type="checkbox"/>
<i>Beginning</i>	<i>Developing</i>	<i>Promising</i>	<i>Proficient</i>	<i>Excellent</i>

- The task of capturing ‘Expressions’ with the shape of ‘Planes’ was done well. (Individual Assessment, Task 2.1b)

<input type="checkbox"/>	<input type="checkbox"/>	<input type="checkbox"/>	<input type="checkbox"/>	<input type="checkbox"/>
<i>Beginning</i>		<i>Promising</i>		<i>Excellent</i>

- The task with of exploring ‘Points’ or ‘Lines’ came out well. (Individual Assessment, Task 2.1c)

<input type="checkbox"/>	<input type="checkbox"/>	<input type="checkbox"/>	<input type="checkbox"/>	<input type="checkbox"/>
<i>Beginning</i>		<i>Promising</i>		<i>Excellent</i>

Principles of 2D Design:

- The 2 compositions of representing ‘Negative Spaces’ in the environment was done well. (Individual Assessment, Task 2.2a)

<input type="checkbox"/>	<input type="checkbox"/>	<input type="checkbox"/>	<input type="checkbox"/>	<input type="checkbox"/>
<i>Beginning</i>	<i>Developing</i>	<i>Promising</i>	<i>Proficient</i>	<i>Excellent</i>

- Listing of examples of Symmetry at Home + the cut-out in paper was done well. (Individual Assessment, Task 2.2b)

- xxxx

<input type="checkbox"/>	<input type="checkbox"/>	<input type="checkbox"/>	<input type="checkbox"/>	<input type="checkbox"/>
<i>Beginning</i>		<i>Promising</i>		<i>Excellent</i>

Structure 2D Design:

- The exploration of 2 tessellating patterns was done well. (Individual Assessment, Task 2.3a)

<input type="checkbox"/>	<input type="checkbox"/>	<input type="checkbox"/>	<input type="checkbox"/>	<input type="checkbox"/>
<i>Beginning</i>	<i>Developing</i>	<i>Promising</i>	<i>Proficient</i>	<i>Excellent</i>

- The drawing of a Golden Spiral was done well. (Individual Assessment, Task 2.3b)

<input type="checkbox"/>	<input type="checkbox"/>	<input type="checkbox"/>	<input type="checkbox"/>	<input type="checkbox"/>
<i>Beginning</i>		<i>Promising</i>		<i>Excellent</i>

Visual Studies and Graphicalisation:

- The 3 variations of the chosen state symbol as sketches were done well.
(Individual Assessment, Task 2.3a)

Beginning *Developing* *Promising* *Proficient* *Excellent*

- 3 variations of the chosen state symbol as Icons/Symbols were done well.
(Individual Assessment, Task 2.3b)

Beginning *Promising* *Excellent*

Other References:

Other suggested References:

1. Elements of Design

https://dsource.in/tool/element_of_design/

2. Fundamentals of Design – Line, Shape, Form, Texture and Balance:

<https://www.youtube.com/watch?v=YqQx75OPRa0>

3. Principles of Design

<https://www.youtube.com/watch?v=ZK86XQ1iFVs>

4. Fibonacci Series and the Golden Ratio:

https://www.sciencefocus.com/science/what-is-the-fibonacci-sequence/?utm_source=pocket-newtab-intl-en

5. Designed by Apple - showcasing Elements of Design:

<https://www.youtube.com/watch?v=xpmfTNjpF8U>

6. Patterns in Nature:

<https://www.youtube.com/watch?v=g2MdUhk9QWw>