

Human Health and Diseases

Multiple Choice Questions (MCQs)

Q. 1 The term 'Health' is defined in many ways. The most accurate definition of the health would be

- (a) health is the state of body and mind in a balanced condition
- (b) health is the reflection of a smiling face
- (c) health is a state of complete physical, mental and social well-being
- (d) health is the symbol of economic prosperity.

Ans. (c) Health does not, simply mean 'absence of disease' or 'physical fitness'. It could be defined as a state of complete physical, mental and social well being. When people are healthy, they are happy with smiling face and more efficient at work. This increases productivity and brings economic prosperity. It also increases longevity of people and reduces infant and maternal mortality.

Q. 2 The organisms which cause diseases in plants and animals are called

- (a) pathogens
- (b) vectors
- (c) insects
- (d) worms

Ans. (a) A wide range of organisms including bacteria, viruses, fungi, protozoans, helminths, etc., cause diseases in plants and animals. Such disease causing organisms are called pathogens. While vectors are the carriers of pathogens which may be insects or worms.

Q. 3 The chemical test that is used for diagnosis of typhoid is

- (a) ELISA test
- (b) ESR test
- (c) PCR test
- (d) Widal test

💡 Thinking Process

*Typhoid fever is caused by pathogenic bacterium *Salmonella typhi*.*

Ans. (d) Typhoid fever could be confirmed by **Widal test**, while

ELISA (Enzyme Linked Immunosorbent Eassy) is a widely used as diagnostic test for AIDS, **PCR test** is used to identify the genome sequences of organisms.

ESR (Erythrocyte Sedimentation Rate) test is a type of blood test.

Q. 4 Diseases are broadly grouped into infectious and non-infectious diseases. In the list given below, identify the infectious diseases.

- | | |
|----------------|----------------|
| I. Cancer | II. Influenza |
| III. Allergy | IV. Smallpox |
| (a) I and II | (b) II and III |
| (c) III and IV | (d) II and IV |

Ans. (d) Influenza, commonly known as the 'flu' is an infectious disease of birds and mammals caused by influenza viruses. The most common symptoms are chill, fever, runny nose, sore throat, muscle pain, headache, coughing, weakness/fatigue and discomfort.

Cancer is defined as an uncontrolled division or proliferation of cells without any differentiation. It is a non-infectious disease caused by the agents called carcinogens.

Smallpox is a serious, highly contagious and often life threatening disease characterised by a rash and (blisters) on the face, arms and legs. It is caused by the Variola virus. It get transmitted from a person to others by various means like sneeze, saliva, contaminated body fluids, etc.

Allergy is the exaggerated response of the immune system to certain antigens in the environment (pollen, dust, mites, molds, cloth fibres, animal hair, etc). It occurs due to the release of chemicals like histamine and serotonin from the mast cells. It is non-infectious response.

Q. 5 The sporozoites that cause infection when a female *Anopheles* mosquito bites a human being are formed in

- | | |
|---------------------------------|------------------------|
| (a) liver of human | (b) RBCs of mosquito |
| (c) salivary glands of mosquito | (d) intestine of human |

🔦 Thinking Process

Malaria is caused by a protozoan, Plasmodium. The vector of Plasmodium is female Anopheles mosquito which transfers the sporozoites (infectious form) to the human body by biting.

Ans. (c) Sporozoites enter the female *Anopheles* mosquito when they bite an infected person where these sporozoite fertilise and multiply in the stomach wall of the female *Anopheles* and stored in the salivary gland of mosquito till it is again transferred to the human body by a mosquito bite.

After entering the human body the sporozoites reach the liver cells, where they multiply. This is followed by their attack on red blood cells resulting in their rupture. The ruptured RBCs release a toxin called haemozoin, which is responsible for high recurring fever, chills and shivering.

Q. 6 The disease chikungunya is transmitted by

- | | |
|-----------------|-----------------------------|
| (a) house flies | (b) <i>Aedes</i> mosquitoes |
| (c) cockroach | (d) female <i>Anopheles</i> |

🔦 Thinking Process

Disease like dengue and chikungunya are transmitted through insect vectors.

Ans. (b) *Chikungunya* is transmitted by the vector *Aedes* mosquitoes. Whereas housefly is the vector for cholera cockroach transmit jaundice or yellow fever and is a carrier of food and waterborne disease female *Anopheles* is responsible for spreading malaria.

Q. 7 Many disease can be diagnosed by observing the symptoms in the patient. Which group of symptoms are indicative of pneumonia?

- (a) Difficulty in respiration, fever, chills, cough and headache
- (b) Constipation, abdominal pain, cramps and blood clots
- (c) Nasal congestion and discharge, cough, sore throat and headache
- (d) High fever, weakness, stomach pain, loss of appetite and constipation.

💡 Thinking Process

Pneumonia is caused by the pathogenic bacterium Streptococcus pneumoniae and Haemophilus influenza and spreads inhaling droplet/aerosol from infectid person during sneezing or coughing.

Ans. (a)

Symptoms	Diseases
Difficulty in respiration, fever, chills, cough and headache.	Pneumonia
Constipation, abdominal, pain, cramp and blood dots	Amoebiasis
Nasal congestion and discharge, cough, sore throat and headache.	Common cold /influenzae
High fever, weakness stomach pain, loss of appetite and constipation	Typhoid

Q. 8 The genes causing cancer are

- (a) structural genes
- (b) expressor genes
- (c) oncogenes
- (d) regulatory genes

Ans. (c) Normal cells have genes called cellular oncogenes or proto-oncogenes which are present in inactivated state, but under certain conditions (like mutation) these get transformed to cancer causing oncogenes, whereas structural gene, expressor gene and regulatory genes are responsible for regulation of gene expression (operon model).

Q. 9 In malignant tumours, the cells proliferate, grow rapidly and move to other parts of the body to form new tumours. This stage of disease is called

- (a) metagenesis
- (b) metastasis
- (c) teratogenesis
- (d) mitosis

Ans. (b) Cancer is defined as an uncontrolled division or proliferation of cells without any differentiation. Repeated division of cells form a large mass of tissue called tumours. Tumours are of two types *i.e.*, benign (non-cancerous) and malignant (cancerous).

The invasion of cancerous cells (in malignant tumours) from one part to the other parts of body is called metastasis, while metagenesis is the alteration of generation.

Tetragenesis is a prenatal toxicity characterised by structural, functional defects in the developing embryo or fetus. Mitosis is a type of cell division that results in two daughter cells.

Q. 10 When an apparently healthy person is diagnosed as unhealthy by a psychiatrist, the reason could be that

- (a) the patient was not efficient at his work
- (b) the patient was not economically prosperous
- (c) the patient shows behavioural and social maladjustment
- (d) he does not take interest in sports

Ans. (c) Health can be defined as a state of complete physical, mental and social well being. So, when an apparently healthy person is diagnosed as unhealthy by a psychiatrist, the reason could be that the patient shows behavioural and social maladjustment. Due to mental discomfort.

It patient is not efficient at his/her work and donot show interest in routine, social and sports activities it means that he is physically not well and need treatment by a psychiatrist

Q. 11 Which of the following are the reason(s) for rheumatoid arthritic? Choose the correct option.

- I. Lymphocytes become more active
- II. Body attacks self cells
- III. More antibodies are produced in the body
- IV. The ability to differentiate pathogens or foreign molecules from self cells is lost

(a) I and II (b) II and IV (c) III and IV (d) I and III

🔦 **Thinking Process**

Rheumatoid arthritis which affects many people in our society is an auto-immune disease.

Ans. (b) Autoimmunity is an abnormal immune response in which the immune system of the body starts rejecting its own body cells or 'self' cells and molecules. Sometimes, body loose its ability to differentiate between pathogen or foreign molecules from self cell and attacks self-cells. This results in damage to the body.

While if any foreign antigen enters into body the lymphocytes because more active and produces more antibodies in its response in the body.

Q. 12 AIDS is caused by HIV. Among the following, which one is not a mode of transmission of HIV?

- (a) Transfusion of contaminated blood
- (b) Sharing the infected needles
- (c) Shaking hands with infected persons
- (d) Sexual contact with infected persons

Ans. (c) *Transmission of HIV-infection generally occurs by*

- (i) Sexual contact with infected person
- (ii) Transfusion of contaminated blood and blood products.
- (iii) Sharing infected needles as in the case of intravenous drug abusers
- (iv) Infected mother to her child through placenta.

Shaking hands with infected persons is not a mode of transmission of HIV.

Q. 13 'Smack' is a drug obtained from the

- (a) latex of *Papaver somniferum*
- (b) leaves of *Cannabis sativa*
- (c) flowers of *Dhatura pinata*
- (d) fruits of *Erythroxyyl coca*

Ans. (a) Heroin, commonly called smack, is chemically diacetyl morphine which is a white, odourless, bitter, crystalline compound. This is obtained by acetylation of morphine, extracted from the latex of poppy plant (*Papaver somniferum*), but Leaves of *cannabis sativa* commonly called bhang produces cannabinoids.

Flower of *Datura* Active chemical of *Datura* flower is tropane alkaloids mainly scopolamines, hyoscyamine and atropine.

Fruits of *Erythroxyl coca* Cocaine is extracted from the dried leaves and young twigs of *Erythroxyl coca*.

Q. 14 The substance produced by a cell in viral infection that can protect other cells from further infection is

- (a) serotonin (b) colostrum (c) interferon (d) histamine

🔗 **Thinking Process**

Innate immunity is non-specific type of defense, mechanism of the body which is present at the time of birth. This is accomplished by providing different types of barriers to the entry of the foreign agents into our body.

Ans. (c) The cytokine-barriers include interferons. These are the proteins secreted by virus infected cells, which protect non-infected cells from further viral infection.

Serotonin It is a neurotransmitter that leads to depression.

Colostrum It is present in the lactating mother's breast milk, contains antibodies which protect the newborn against disease.

Histamine Histamine is also a neurotransmitter involved in inflammatory response.

Q. 15 Transplantation of tissues/organs to save certain patients often fails due to rejection of such tissues/organs by the patient. Which type of immune response is responsible for such rejections?

- (a) Auto-immune response
(b) Humoral immune response
(c) Physiological immune response
(d) Cell-mediated immune response

Ans. (d) Transplantation is the replacement of a diseased organ or tissue of an individual with healthy organ or tissue of same or another individual. These transplants or graft gets rejected if it is recognised as foreign antigen by the body's immune systems.

Cell mediated immune response, mediated by T-lymphocyte in able to differentiate between self and non-self cells/organ. This type of immune response recognise the body's non-cells or other tissue or organs from other individual as foreign antigen and cause rejection of the graft.

Q. 16 Antibodies present in colostrum which protect the new born from certain diseases is of

- (a) IgG type (b) IgA type
(c) IgD type (d) IgE type

Ans. (b) The yellowish fluid colostrum is secreted by mother during the initial days of lactation has abundant antibodies (IgA) to protect the infant from several diseases.

IgG immunoglobulin (antibody) is most abundant (appro .80%) antibody in human and found in serum IgA is second abundant (approx .10-15%) antibody. It is found in saliva and tear also. IgD and IgE constitute 2-3% of total antibodies which are found in most cells and serum.

Q. 17 Tobacco consumption is known to stimulate secretion of adrenaline and noradrenaline. The component causing this could be.

- (a) nicotine (b) tannic acid
(c) curaimin (d) catechine

Ans. (a) Tobacco has nicotine, which stimulates the adrenal gland to release adrenaline and noradrenaline which in turn increases the blood pressure and heart rate, while tannic acid is a type of polyphenol used as a mordant, curaimin, obtained from cureumin in a pain releiver and catechine derived from catechu is an antioxidant.

Q. 18 Anti venom against snake poison contains

- (a) antigens (b) antigen-antibody complexes
(c) antibodies (d) enzymes

Ans. (c) Snake antivenom is a biological product that typically consists of venom neutralising antibodies derived from a host animal, such as a horse or sheep, it is not considered as antigen or antigen-antibody complex or enzyme.

Q. 19 Which of the following is not a lymphoid tissue?

- (a) Spleen (b) Tonsils (c) Appendix (d) Thymus

Ans. (c) Lymphoid organs are the organs where origin and/or maturation and proliferation of lymphocytes occur.

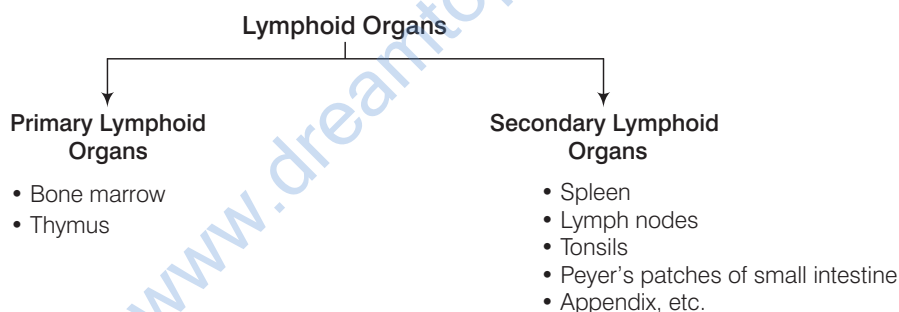

The secondary lymphoid organs provide the sites for interaction of lymphocytes with the antigen, which then proliferate to becomes effector cells.

Appendix is sometime not considered as the lymphoid organ, as it has been proposed to be a vestigial structure connected to the cecum, located near the junction of the small intestine and the large intestine.

Q. 20 Which of the following glands is large sized at birth but reduces in size with ageing?

- (a) Pineal (b) Pituitary
(c) Thymus (d) Thyroid

Ans. (c) The thymus is a lobed organ located near the heart and beneath the breastbone. The thymus is quite large at the time of birth but keeps reducing in size with age and by the time puberty is attained it reduces to a very small size.

While the size of pineal gland (located at brain), pituitary gland (in brain), thyroid (located infront of neck) remains constant in size since birth.

Q. 21 Haemozoin is

- (a) precursor of haemoglobin
- (b) toxin from *Streptococcus*
- (c) toxin from *Plasmodium* species
- (d) toxin from *Haemophilus* species

Ans. (c) Haemozoin is a toxin released by *Plasmodium* species, which is responsible for the chill and high fever recurring every three to four days.

To continue their life-cycle, *Plasmodium* enters the human body as sporozoites and multiply within the liver cells, resulting in the rupture of the RBCs.

The rupture RBCs is associated with release of a toxic substance, haemozoin, while *Streptococcus* produces streptomycin and streptococcal pyrogenic exotoxin which shows haemolytic and *Haemophilus* produces cytolethal distending toxin (HdCDT) which inhibit mammals cell proliferation.

Q. 22 One of the following is not the causal organism for ringworm

- (a) *Microsporum*
- (b) *Trichophyton*
- (c) *Epidermophyton*
- (d) *Macrosporum*

Ans. (d) Ringworm infections are caused by fungi belonging to the genera *Microsporum*, *trichophyton* and *Epidermophyton*.

Macrosporum is an ectomycorrhizal zoosporic fungus causing diseases of economically important vascular plants.

Q. 23 A person with sickle-cell anaemia is

- (a) more prone to malaria
- (b) more prone to typhoid
- (c) less prone to malaria
- (d) less prone to typhoid

💡 Thinking Process

Sickle-cell anaemia is an autosome-linked recessive trait that can be transmitted from heterozygous carrier parents to the offspring.

Ans. (c) Sickle-cell anaemia is related to malaria not to typhoid and person suffering from sickle-cell anaemia are resistant to malarial parasite as RBC of sickle-cell anaemic patients is distorted in shape that not affected by *Plasmodium* sp.

It is known that heterozygotes (Hb^S/Hb^A), having both types of haemoglobin show resistance to malarial infection because the body targets the *P. falciparum* infected cells for destruction.

In contrast, individuals homozygous for normal haemoglobin (Hb^A/Hb^A) suffer high mortality rates in early childhood due to malarial infection.

Very Short Answer Type Questions

Q. 1 Certain pathogens are tissue/organ specific. Justify the statement with suitable example.

Ans. Certain pathogens are tissue/organ specific as they are adapted to overcome the resistance mechanisms of those tissues and organs, e.g., the pathogens that enter the gut must know a way of surviving in the stomach at low pH and resistant to various digestive enzymes.

Q. 2 The immune system of a person is suppressed. In the ELISA test, was found positive to a pathogen.

- (a) Name the diseases the patient is suffering from.
- (b) What is the causative organisms?
- (c) Which cells of body are affected by the pathogen?

Ans. The immune system of a person is suppressed. In the ELISA test, he was found positive to a pathogen.

- (a) The patient is suffering from AIDS.
- (b) AIDS is caused by Human Immuno deficiency Virus (HIV). It is a retro virus containing RNA as genetic material.
- (c) Macrophages and helper T-cells are affected by the pathogen.

Q. 3 Where are B-cells and T-cells formed? How do they differ from each other?

💡 Thinking Process

Lymphocytes are of two types i.e., T-lymphocytes or T-cells and B-lymphocytes or B-cells.

Ans. Both type of lymphocytes and other cells of the immune system are produced in the bone marrow.

B and T-cells are different from each other in the following aspects

B-lymphocytes (B-cell)	T-lymphocytes (T-cell)
They mature in bone marrow.	They mature in thymus gland.
They produce antibody against antigen.	They directly attack the antigen or attach B-cells to produce antibody.
They do not respond to organ transplantation.	They respond to organ transplantation.

Q. 4 Given below are the pairs of pathogens and the diseases caused by them. Which out of these is not a matching pair and why?

(a) Virus	Common cold
(b) <i>Salmonella</i>	Typhoid
(c) <i>Microsporium</i>	Filariasis
(d) <i>Plasmodium</i>	Malaria

Ans. (c) *Wuchereria* species *bancrofti* and *W. malayi*, the filarial worms cause a slowly developing chronic inflammation of the organs in which they live for many years, usually the lymphatic vessels of the lower limbs and the disease is called elephantiasis or filariasis.

Fungi belonging to the genera *Microsporium*, *Trichophyton* and *Epidermophyton* are responsible for ringworms which is one of the most common infectious diseases in man.

Q. 5 What would happen to immune system, if thymus gland is removed from the body of a person?

💡 Thinking Process

Thymus is the primary lymphoid organ. In thymus gland, immature lymphocytes differentiate into antigen-sensitive lymphocytes.

Ans. If thymus gland is removed from the body of a person, his immune system will become weak. As a result the person's body becomes prone to infectious diseases.

Q. 6 Many microbial pathogens enter the gut of humans along with food. What are the preventive barriers to protect the body from such pathogens? What type of immunity do you observe in this case?

Ans. Many microbial pathogens enter the gut of humans along with food.

The preventive barriers to protect the body from such pathogens are as follows

- (i) the mucus coating of the epithelium lining of the gut helps in trapping microbes entering the body.
- (ii) saliva in the mouth and hydrochloric acid in gastric juice secreted by stomach prevent microbial growth.

This type of immunity is innate immunity. It is present from birth and is inherited from parents. The innate immunity remains throughout life.

Q. 7 Why is mother's milk considered the most appropriate food for a new born infant?

💡 Thinking Process

Colostrum is the first yellowish milk secreted during initial days of lactation.

Ans. Colostrum contains several antibodies (especially IgA) which are absolutely essential for developing resistance for the new-born babies.

Q. 8 What are interferons? How do interferons check infection of new cells?

Ans. In response to viral infections our body produces glycoproteins called interferons. Such type of barriers of innate immunity is called cytokine barrier. Interferons protect the non-infected cells from further viral infection.

Q. 9 In the figure, structure of an antibody molecule is shown. Name the parts A, B and C.

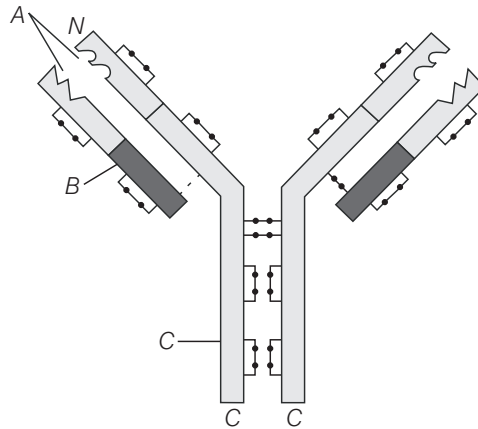

Ans.

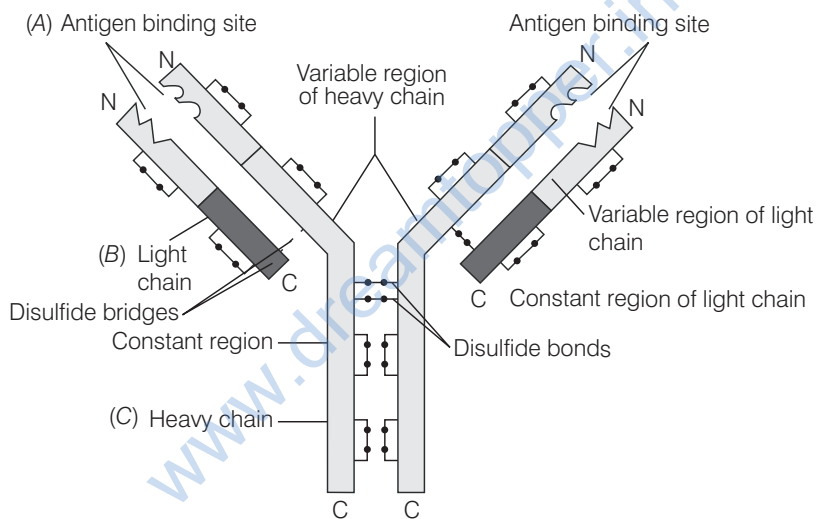

Structure of an antibody molecule

Q. 10 If a regular dose of drug or alcohol is not provided to an addicted person, he shows some withdrawal symptoms. List any four such withdrawal symptoms.

Ans. *The withdrawal symptoms are*

- | | |
|--------------|----------------|
| (i) anxiety | (ii) shakiness |
| (iii) nausea | (iv) sweating |

Q. 11 Why is it that during changing weather, one is advised to avoid closed, crowded and air conditioned places like cinema halls etc?

Ans. During changing weather one is advised to avoid crowded places, because changing seasons are the time when infectious agents are more prevalent as moist condition favours pathogen to grow fast and people are more vulnerable as their body system is busy in adapting the changing environmental conditions of temperature humidity, etc and they get infected to there pathogen easily.

Q. 12 The harmful allele of sickle-cell anaemia has not been eliminated from human population. Such afflicted people derive some other benefit. Discuss.

Ans. Sickle-cell anaemia still persists in the population despite being harmful because this mutation can also be beneficial in certain conditions.

The mutant Hb^S type haemoglobin is found at high frequencies (up to 20% and above) in the tropical Africa.

It is known that heterozygotes (Hb^S/Hb^A), having both types of haemoglobin show resistance to malarial infection because the body targets the *Plasmodium falciparum* infected cell for destruction. In contrast, individuals homozygous for normal haemoglobin (Hb^A/Hb^A) suffer high mortality rates in early childhood due to malarial infection.

Thus, the allele for sickle cells has been maintained because heterozygotes have a higher reproductive success than either of the two possible homozygotes.

Q. 13 Lymph nodes are secondary lymphoid organs. Explain the role of lymph nodes in our immune response.

Ans. Lymphoid Organs immune system of human beings consists of lymphoid organs. The organs whereas called the maturation and proliferation of lymphocytes occurs are called lymphoid organs. Lymphoid organs are of two types. These are

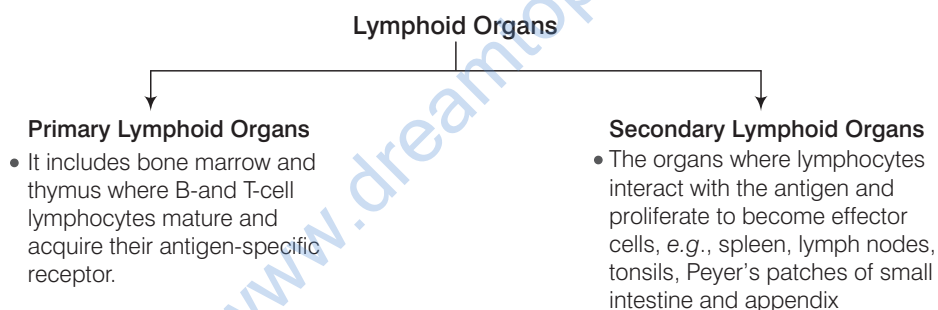

Lymph nodes are small solid structures present at different points along the lymphatic system. They trap the microorganisms or other antigens that enter the lymph and tissue fluid. Antigens trapped in the lymph nodes activate the lymphocytes and produce an immune response.

Q. 14 Why is an antibody molecule represented as H₂L₂?

Ans. Each antibody molecule has four peptide chains, two small called light chains (represented by L) and two longer called heavy chains (represented by H). Hence, an antibody is represented as H₂L₂.

Q. 15 What does the term 'memory' of the immune system mean?

Ans. When the body encounters a pathogen for the first time, it mounts an immune response by generating antibodies. This response is of low intensity. Subsequent encounter with the same pathogen elicits a highly intensified secondary response.

This is ascribed to the fact that our body appears to have memory of the first encounter. This type of secondary immune response is elicited by memory T-cells, B-cell which keep ready to mount a rapid and vigorous attack as soon as the same pathogen infects the body again.

Q. 16 If a patient is advised anti retroviral therapy, which infection is he suffering from? Name the causative organism.

Ans. The patient is suffering from AIDS. The causative agent is HIV virus, a member of 'retrovirus group'.

Short Answer Type Questions

Q. 1 Differentiate between active immunity and passive immunity.

Ans. *Differentiate between active immunity and passive immunity*

Active Immunity	Passive Immunity
It is developed due to contact with pathogen or its antigen.	It is developed when ready-made antibodies are injected into the body.
It has no side effects .	It may cause a reaction.
It is slow but long lasting.	It is fast but lasts only for few days.
It takes time to develop its response.	It is used when the immune response has to be faster.
<i>e.g.</i> , vaccination for polio, etc	<i>e.g.</i> , administration of tetanus antitoxins, etc.

Q. 2 Differentiate between benign tumour and malignant tumour.

Ans. *Differentiate between benign tumour and malignant immunity*

Benign Tumour	Malignant Tumour
It is a non-cancerous tumour.	It is a cancerous tumour.
Benign tumour does not show metastasis and is non-invasive.	It shows metastasis and thus invades other body parts.
It stops growth after reaching a certain size.	Malignant tumour shows indefinite growth.
Limited adherence occurs amongst cells of benign tumour.	There is no adherence amongst cells. They tend to slip past one another.
It is less fatal to the body.	It is more fatal to the body.

Q. 3 Do you consider passive smoking is more dangerous than active smoking? Why?

Ans. Passive smoking can be equally dangerous because it exposes the persons to the same harmful effect of smoke.

Passive or second hand smoking means being in the same room or place, where some one is smoking and getting exposed to smoke in the surrounding air.

Once inhaled, the smoke can trigger release of mucus in the bronchioles that blocks the airways. This induces coughing. But prolonged exposures can lead to bronchitis emphysema, respiratory tract infections and eventually lung cancer.

Q. 4 'Prevention is better than cure'. Comment.

Ans. Prevention is always better than cures because some diseases cause extensive damage to the body tissues or organs and have a

- (i) Negative effect on their capacity to function.
- (ii) Permanent or long term debilitating effect.
- (iii) Negative mental and psychological effect.
- (iv) Financial burden.

Prevention, therefore is easier and effective, than cure of a disease.

Q. 5 Explain any three preventive measures to control microbial infections.

Ans. Preventive measures to control microbial infection include

- (i) Maintenance of personal and public hygiene by
 - (a) Proper cleanliness standards and practices .
 - (b) Proper disposal of waste.
 - (c) Periodic cleaning of water reservoirs, etc.
- (ii) Control or elimination of vectors that transmit diseases by
 - (a) Checking water stagnation and garbage accumulation.
 - (b) Using disinfectants or biological methods to check their breeding and spread.
- (iii) Proper immunisation by vaccination, wherever available to control or completely eradicate infectious diseases.

Q. 6 In the given flow diagram, the replication of retro virus in a host is shown. Observe and answer the following questions.

(a) Fill in (A) and (B)

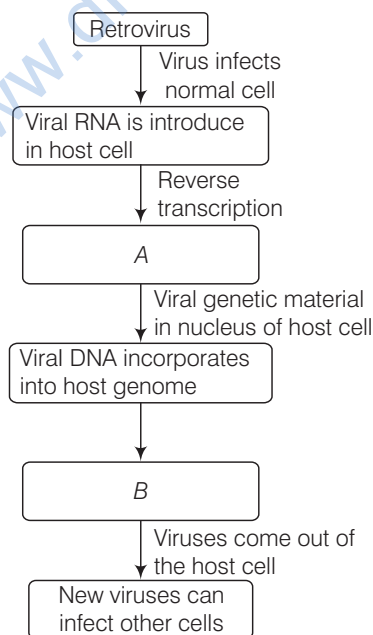

(b) Why is the virus called retrovirus?

(c) Can the infected cell survive, while viruses are being replicated and released?

Ans. (a)

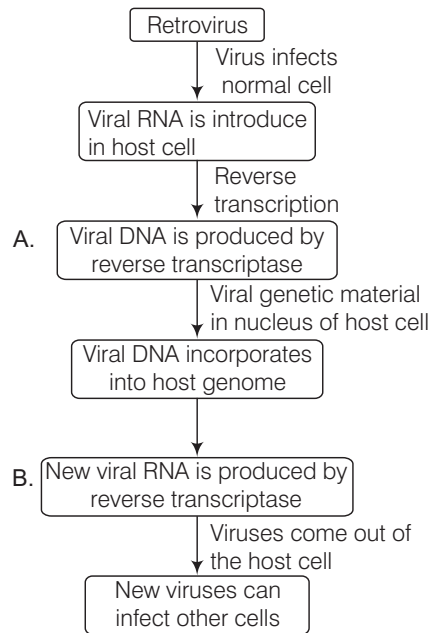

(b) The virus is called retro virus because it does not follow the central dogma of biology (DNA → RNA → Proteins).

Its genetic material is RNA that is transcribed to DNA using enzyme reverse transcriptase.

(c) Yes, the infected cell can survive, while viruses are being replicated and released.

Q. 7 Maintenance of personal and public hygiene is necessary for prevention and control of many infectious diseases. Justify the statement giving suitable examples.

Ans. Diseases which are easily transmitted from one person to another, are called infectious diseases.

For prevention and control of such diseases, maintenance of personal and public hygiene is necessary, for this purpose, some common preventive measures should be taken as follows

- (i) **Education** People should be educated about communicable disease to protect themselves from such diseases.
- (ii) **Isolation** The infected person should be kept isolated to minimise the spread of infection.
- (iii) **Vaccination** People should get vaccination on time to avoid infection.
- (iv) **Sanitation** The sanitation should be improved to avoid infection from polluted water, contaminated food, etc.
- (v) **Eradication of Vectors** The breeding places of vectors must be destroyed and adult vectors should be killed by suitable methods.
- (vi) **Sterilisation** The patient's surroundings and articles of use should be completely sterilised to reduce the chances of infection.

Q. 8 The following table shows certain diseases, their causative organisms and symptoms. Fill the gaps.

Diseases	Causative organisms	Symptoms
Ascariasis	<i>Ascaris</i>	—
—	<i>Trichophyton</i>	Appearance of dry, scaly lesions on various parts of the body
Typhoid	—	High fever, weakness, headache, stomach pain and constipation.
Pneumonia	<i>Streptococcus pneumoniae</i>	—
—	<i>Rhino viruses</i>	Nasal congestion and discharge, sorethroat, cough headache
Filariasis	—	Inflammation in lower limbs

Ans.

Diseases	Causative organisms	Symptoms
Bacterial Typhoid	<i>Salmonella typhi</i>	High fever, weakness, stomach pain, constipation, headache and loss of appetite. Intestinal perforation and death may occur in severe cases.
Pneumonia	<i>Streptococcus pneumoniae</i> and <i>Haemophilus influenzae</i>	Fever, chills, cough and headache. In severe cases, the lips and finger nails may turn gray to bluish in colour.
Viral Common cold	<i>Rhino viruses</i>	Nasal congestion and discharge, sore throat, hoarseness, cough, headache tiredness.
Worms Ascariasis	<i>Ascaris lumbricoides</i>	Internal bleeding, muscular pain, fever, anaemia and blockage of the intestinal passage.
Filariasis	<i>Wuchereria (W. bancrofti and W. malayi)</i>	Chronic inflammation and deformation of the organs and genital organs.
Ring worms	<i>Microsporum, Trichophyton and Epidermophyton</i>	Appearance of dry, scaly lesions on various parts of the body such as skin, nails and scalp.
Parasitic Malaria	<i>Plasmodium (P. vivax, P. malariae and P. falciparum)</i>	High fever, chills, sweating, fatigue, weakness, loss of appetite.
Amoebiasis	<i>Entamoeba histolytica</i>	Constipation, abdominal pain and cramps, stools with excess mucous and blood clots.

Q. 9 The outline structure of a drug is given below.

- Which group of drugs does this represent?
- What are the modes of consumption of these drugs?
- Name the organ of the body which is affected by consumption of these drugs.

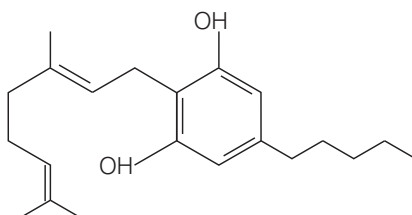

Ans. (a) It represents cannabinoids group of drugs.

(b) Mode of consumption—nasal inhalation or oral in take.

(c) Organs affected—heart and cardiovascular system.

Q. 10 Give the full form of CT and MRI. How are they different from each other? Where are they used?

Ans. CT-Computed Tomography. It uses X-rays to generate 3-D images of internal organs.

MRI-Magnetic Resonance Imaging. It uses strong magnetic fields and non-ionising radiations to detect pathological and physiological changes in the living tissue accurately.

Both are used in cancer detection.

Q. 11 Many secondary metabolites of plants have medicinal properties. It is their misuse that creates problems. Justify the statement with an example.

Ans. Drugs like barbiturates, amphetamines, benzodiazepines, lysergic acid diethylamides (LSD) and other similar drugs, that are normally used as medicines to help patients coping with mental illnesses like depression and insomnia. Morphine is a very effective sedative and painkiller and is very useful in patients who have undergone surgery.

Misuse of plant metabolites fruits and seeds in amounts/frequency more than prescribed for medicinal purposes can impair one's physical, physiological or functional behaviour creating problem for the society and slowly moves towards the eternal truth (death).

Q. 12 Why cannabinoids are banned in sports and games?

Ans. Cannabinoids are banned in sports, as athletes misuse these drugs to enhance their performance. But drugs obtained from cannabinoids can cannatnads have, a serious negative effect on their general health and in long term can hamper the normal functioning of organ system.

Q. 13 What is secondary metabolism?

Ans. Secondary metabolism (also called specialised metabolism) is a term for pathways and metabolites are small molecule produced by metabolism that are not absolutely required for the survival of the organism.

In case of plant, metabolites aid in the growth and development of plants. It also facilitates the primary metabolism.

Q. 14 Drugs and alcohol give short-term 'high' and long-term 'damages'.

Ans. Curiosity, need for adventure and excitement and experimentation, constitute common causes, which motivate youngsters towards drug and alcohol use.

The frequent use of drugs/alcohols drive people to take them even when these are not needed, or even their use becomes self-destructive.

Short-term effects of drugs/alcohols

- A relaxing effect
- Lowered inhibitions
- Slow reflexes
- Reduced coordination
- Sensations and perceptions that are less clear
- Reduced tension
- Poor concentration
- Slow reaction time
- Slower brain activity

Long-term effects of drugs/alcohols

- Disrupts normal brain development
- Liver damage and cirrhosis of the liver
- Brain cells die, decreasing brain mass
- Stomach and intestinal ulcers and destroyed organs
- Blood pressure increases, causing heart disease, heart attack or stroke
- Male sperm production decreases
- Lower levels of iron and vitamin-B, causing anaemia
- Alcoholism
- Death and
- Fetal alcohol syndrome in unborn children

Q. 15 Diseases like dysentery, cholera, typhoid, etc., are more common in over crowded human settlements. Why?

Ans. Dysentery, cholera and typhoid are more common in crowded settlements because these are infectious diseases and spread from person to person contact. Water gets contaminated with the excreta of infected people and causes the spread of infection to other people.

Q. 16 From which plant cannabinoids are obtained? Name any two cannabinoids. Which part of the body is effected by consuming these substances?

Ans. Cannabinoids are obtained from the inflorescence of the plant *Cannabis sativa*. Marijuana, hashish, charas, ganja are some cannabinoids. These chemicals interact with cannabinoid receptors of the body, mainly present in the brain. Cardiovascular system of the body is effected adversely by consuming these substances.

Q. 17 In the metropolitan cities of India, many children are suffering from allergy/asthma. What are the main causes of this problem. Give some symptoms of allergic reactions.

💡 Thinking Process

Allergy is the exaggerated response of the immune system of certain antigens present in the environment.

Ans. In metropolitan cities life style is responsible in lowering of immunity and sensitivity to allergens. More polluted environment like dust in surroundings increases the chances of allergy in children. Some symptoms of allergic reactions are sneezing, watery eyes, running nose and difficulty in breathing.

Q. 18 What is the basic principle of vaccination? How do vaccines prevent microbial infections? Name the organism from which hepatitis-B vaccine is produced.

Ans. The principle of vaccination is based on the property of 'memory' of immune system. In vaccination, a preparation of antigenic proteins or inactivated/live but weakened pathogens is introduced into the body. The antigens generate primary immune response by producing antibodies along with memory B-cells and T-cells. When the vaccinated person is attacked by the same pathogens, the existing memory B-cells and T-cells recognise the antigen and overwhelm the invaders with massive production of lymphocytes and antibodies. Hepatitis-B vaccine is produced from yeast.

Q. 19 What is cancer? How is a cancer cell different from the normal cell? How do normal cells attain cancerous nature?

Ans. An abnormal and uncontrolled division of cells is termed as cancer. Genes called cellular oncogenes (c-onc) or proto-oncogenes present in normal cells when activated under certain conditions lead oncogenic transformation of the normal cells leading cancer. *A cancer cell is different from the normal cell in following ways*

Cancer cell	Normal cell
Cancer cells divide in an uncontrolled manner.	Normal cells divide in a controlled manner.
The cells do not show contact inhibition.	The cells show contact inhibition.
Life span is indefinite.	Life span is definite.

Q. 20 A person shows strong unusual hypersensitive reactions when exposed to certain substances present in the air. Identify the condition. Name the cells responsible for such reactions. What precaution should be taken to avoid such reactions.

Ans. If a person is hypersensitive to certain substance present in the air, he may be allergic to it. Mast cells release certain chemicals, e.g., histamine and serotonin, in response to this substance, that result in allergic reaction. Precaution taken to prevent such reaction is to avoid the allergens responsible for particular allergy.

Q. 21 For an organ transplant, it is an advantage to have an identical twin. Why?

Ans. For an organ transplant, it is an advantage to have an identical twin because the organ will have same surface markers and therefore, the recipient's immune system will not identify it as foreign and will not react against it. In case of different surface markers, the immune system starts a reaction, kills the foreign tissue or rejects it.

Q. 22 What are lifestyle diseases? How are they caused? Name any two such diseases.

Ans. Life style disease are caused by specific food habits, work related posture or exposure to harmful radiations or substances, lack of physical exercise, mental stress, etc. e.g., cancer, alcoholism, heart disease, etc.

Q. 23 If there are two pathogenic viruses, one with DNA and other with RNA, which would mutate faster? And why?

Ans. RNA mutates faster than DNA.

DNA is more stable and also has better repair mechanisms that correct the changes in base pairs as soon as it is introduced.

Long Answer Type Questions

Q. 1 Represent schematically the life-cycle of a malarial parasite.

Ans. The life-cycle of a malarial parasite

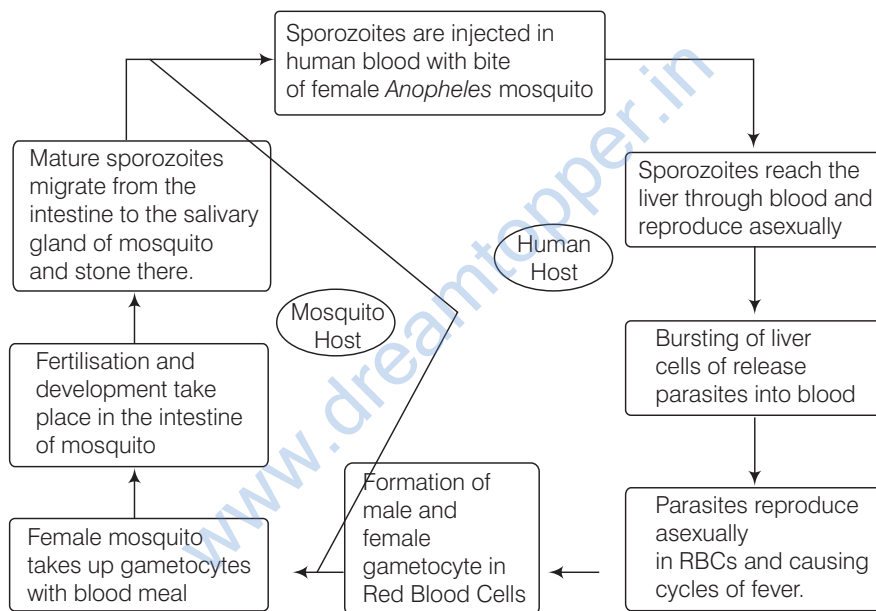

Q. 2 Compare the life style of people living in the urban areas with those of rural areas and briefly describe how the life style affects their health.

Ans. People think that the city life is better than village life. However, there are so many advantages as well as disadvantages of urban life and rural life

Advantages of Urban (city) Life

The city life is more comfortable as there are lot of facilities in the city. There are more opportunities for people to progress their lives and they have more opportunities for making money.

Children living in the city can get a good education, in the town than in the village. When a person falls ill, there are good government and private hospital in the city to get treatment. There are large shopping complexes, banks, offices, cinemas, clubs, hospitals, etc., in and around the city for recreations.

People in the city have better transport facilities than the village. There is electricity, highway, communication, telecommunication, plumb facilities in the city. So, people can lead a comfortable and enjoyable life in the city.

Disadvantages of Urban (city) Life

Although living in the city has many advantages there are some disadvantages too. The cost of living is very high in the city. Goods are expensive, no fresh air and pure water is present. The environment is polluted with dust, smoke, garbage and gases from factories.

Most of the people who live in the city are corrupted, so there are lots of crimes in the city. Many thefts and murders often take place in the city.

The city is always busy and noisy. There are a lot of vehicles and people in the road. The streets are dusty and unclean. So, it is hard to lead a healthy life in the city.

Advantages of Rural (village) Life

The people of the village live in unity and peace. The villagers earn money enough for live very hardly. So, they live in less competition with each other. They have more friends in the community.

The village people always try to protect their traditional habits and culture. The village has clean air and the environment is very beautiful. The village has less noise and rush. So, the pollution is less.

The village do not have lot of vehicles. So, roads are less dangerous for driving or cycling. They can get fresh vegetables and fresh fruits. The environment of the village is pleasant and silent and it has scenic beauty.

Disadvantages of Rural (village) Life

People living in rural area have to face many problems like lack of good education, proper medical facilities, transportation, electricity, telecommunication, etc.

Life style affects human health and cause many diseases due to specific food habits, work related posture or exposure to harmful radiation or substances, lack of physical exercise, mental stress, etc. Some life style diseases are cancer, alcoholism, heart diseases, etc.

Q. 3 Why do some adolescents start taking drugs. How can this be avoided?

Ans. *The reasons why adolescents and youngsters starts consumption of drugs are*

- (i) Curiosity of child motivates him/her to do experiment.
- (ii) For adventure and excitement.
- (iii) Peer group pressure.
- (iv) Desire to do more physical and mental work.
- (v) To overcome frustration and depression, due to failure in examinations or in other activities.
- (vi) Unstable or unsupportive family structures.

The following measures can be taken to avoid drug abuses

- (i) Avoid undue pressure on child to perform beyond his/her capability in studies, sports or any other activities.
- (ii) Education and counselling are very important to face problem of stress and failure in life.
- (iii) Seeking help from parents, elders and peers. This would help the young to share their feelings and concern.
- (iv) Looking for danger signs and taking appropriate measures to treat them.
- (v) Seeking professional and medical help for de-addiction and rehabilitation.

Q. 4 In your locality, if a person is addicted to alcohol, what kind of behavioural changes do you observe in that person? Suggest measures to overcome the problem.

Ans. If a person is addicted to alcohol, it will give rise to some behavioural changes in that person. Alcoholic drinks are costly and most drinkers, because of their selfish habits, deprive their children and other members of the family of the basic needs.

The drinking of alcohol is invariably associated with social crimes and dissolution of moral and cultural inhibitions. Violence and other corrupt practices in the community are often directly or indirectly due to the consumption of alcohol.

Measures that should be taken to overcome the above mentioned problem are

- (i) **Avoid Undue Peer Pressure** Every person has his/her own choice and personality, which should be kept in mind. So he/she should not be pressed unduly to do beyond his/her capacities, in work condition and other in social get together or activities.
- (ii) **Education and Counselling** Helps to overcome the problems, like stresses, disappointments and failure in life. One should utilise a himself/herself energy in some beneficial activities like sports, music, reading, yoga and other extra curricular activities.
- (iii) **Seeking Help from Parents and Peers** In case of minors, whenever, there is any problem, one should seek help and a guidance from parents and peers. Help should be taken from close and trusted friends. This would help young to share their feelings of anxiety and wrong doings.
- (iv) **Looking for Danger Signs** If friends find someone using drugs or alcohol, they should bring this to the notice of parents or teacher so that appropriate measures can be taken to diagnose the illness and the causes. This would help in taking proper remedial steps or treatment.
- (v) **Seeking Professional and Medical Helps** Highly qualified psychologists, psychiatrists and de-addiction and rehabilitation programmes can help individuals who are suffering from drug/alcohol abuse.

If such help is provided to the affected persons, with sufficient efforts and will power, the patient could be completely cured and lead normal and healthy life.

Q. 5 What are the methods of cancer detection? Describe the common approaches for treatment of cancer.

Ans. Early detection of cancer is essential. *The methods of cancer detection and diagnosis are as follows.*

- (i) Biopsy and histo-pathological studies of the tissue/ blood/ bone marrow.
- (ii) Tests for increased cell counts (in the case of leukaemia blood cancer).
- (iii) Techniques like radiography (use of X-rays), CT (computed tomography) and MRI (Magnetic Resonance Imaging) to detect cancers of the internal organs.
- (iv) Detection of cancer specific antigens.
- (v) Molecular biology techniques to detect genes in individuals with inherited susceptibility to certain cancers.

The common approaches for treatment of cancer

- (i) Surgical removal of tumour.
- (ii) Irradiation of tissue to kill cancerous cells.
- (iii) Immunotherapy using interferon to boost cancer cell killing.

Q. 6 Drugs like LSD, barbiturates, amphetamines, etc., are used as medicines to help patients with mental illness. However, excessive doses and abusive usage are harmful. Enumerate the major adverse effects of such drugs in humans.

Ans. Harmful effects of drugs like LSD, barbiturates, are

- (i) Anxiety, shakiness, nausea and sweating, loss of mind control.
- (ii) Reckless behaviour, vandalism and violence.
- (iii) Lack of interest in personal hygiene, fluctuations in weight and appetite.
- (iv) Withdrawal, isolation, depression, fatigue, aggressive behaviour.
- (v) Social adjustment problems
- (vi) Withdrawal symptoms can be severe and life threatening.
- (vii) Excessive doses of drugs may lead to coma and death may occur due to respiratory failure, heart failure or cerebral haemorrhage.

Q. 7 What is Pulse Polio Programme of Government of India? What is OPV? Why is it that India is yet to eradicate polio?

Ans. Pulse Polio is an immunisation campaign established by the Government of India in 1995-96 to eradicate poliomyelitis (polio) in India by vaccinating all children under the age of five years orally against polio virus.

This project deals with the ways to fight poliomyelitis through a large scale immunisation programme, co-operating with various international institutions, state governments and Non-Governmental Organisations. In 1995, following the polio eradication initiative of World Health Organisation (1988), India launched Pulse Polio Immunisation Program along with Universal Immunisation Program which aimed at 100% coverage.

Having made on unprecedented progress in polio eradication, India is now gearing up to be declared polio free by 2014 by guarding itself against the import of polio virus from neighbouring countries and by boosting routine immunisation.

Oral Polio Vaccine

Oral Polio Vaccine (OPV) is a live-attenuated vaccine, produced by the passage of the virus through non-human cells at a sub-physiological temperature, which produces spontaneous mutations in the viral genome.

OPV also proved to be superior in administration, eliminating the need for sterile syringes and making the vaccine more suitable for mass vaccination campaigns. OPV also provides long lasting immunity than the salk vaccine.

One dose of OPV produces immunity to all three poliovirus serotypes in approximately 50% of recipients. India is yet to eradicate polio because in spite of many initiatives taken by government, few cases has been reported.

The last reported cases of polio in India was in West Bengal and Gujarat on 13 January 2011. Earlier this year, the **World Health Organisation** (WHO) had removed India from the list of polio-endemic countries. If no fresh case is reported till 2014, the country will be declared polio free.

July 30, 2013 a nine-month old boy from Navi Mumbai has been found positive for Vaccine-Derived Polio-Virus(VDPV) type 2 and was on ventilator at BJ Wadia Hospital in Parel. This is the fourth such case recorded in the country that year.

In India the main obstacle in the eradication of polio had been the refusal of polio vaccine by certain communities on account of illiteracy and misinformation.

Q. 8 What are recombinant DNA vaccines? Give two examples of such vaccines. Discuss their advantages.

Ans. Recombinant DNA vaccines are made up of a small circular DNA (plasmid) that has very tiny piece of pathogen DNA incorporated in it to produce one or two specific proteins of the pathogen.

This recombinant DNA is introduced in to the bacteria or yeast cells, where it can use cell's machinery to produce polypeptides of pathogen. These are used as vaccine to trigger a range of immune responses.

Vaccines produced by using this approach allow large scale production. e.g.,

- (i) Hepatitis-B vaccine produced from yeast.
- (ii) Bird flu DNA vaccine.

Advantages

- (i) Recombinant DNA vaccines are advantageous over killed or attenuated vaccines since, they does not get virulent or mutated again as it is seen in case of attenuated vaccines.
- (ii) Secondly these are highly pure, specific and elicits strong immune response.