

6

Application of Derivatives

Short Answer Type Questions

Q. 1 A spherical ball of salt is dissolving in water in such a manner that the rate of decrease of the volume at any instant is proportional to the surface. Prove that the radius is decreasing at a constant rate.

Thinking Process

First, let V be the volume of the ball and S be the surface area of the ball and then by using $\frac{dV}{dt} \propto S$, we can prove the required result.

Sol. We have, rate of decrease of the volume of spherical ball of salt at any instant is \propto surface. Let the radius of the spherical ball of the salt be r .

$$\therefore \text{Volume of the ball (V)} = \frac{4}{3} \pi r^3$$

$$\text{and surface area (S)} = 4\pi r^2$$

$$\therefore \frac{dV}{dt} \propto S \Rightarrow \frac{d}{dt} \left(\frac{4}{3} \pi r^3 \right) \propto 4\pi r^2$$

$$\Rightarrow \frac{4}{3} \pi \cdot 3r^2 \cdot \frac{dr}{dt} \propto 4\pi r^2 \Rightarrow \frac{dr}{dt} \propto \frac{4\pi r^2}{4\pi r^2}$$

$$\Rightarrow \frac{dr}{dt} = k \cdot 1 \quad [\text{where, } k \text{ is the proportionality constant}]$$

$$\Rightarrow \frac{dr}{dt} = k$$

Hence, the radius of ball is decreasing at a constant rate.

Q. 2 If the area of a circle increases at a uniform rate, then prove that perimeter varies inversely as the radius.

Sol. Let the radius of circle = r And area of the circle, $A = \pi r^2$

$$\therefore \frac{d}{dt} A = \frac{d}{dt} \pi r^2$$

$$\Rightarrow \frac{dA}{dt} = 2\pi r \cdot \frac{dr}{dt} \quad \dots(i)$$

Since, the area of a circle increases at a uniform rate, then

$$\frac{dA}{dt} = k \quad \dots(ii)$$

where, k is a constant.

From Eqs. (i) and (ii),

$$2\pi r \cdot \frac{dr}{dt} = k$$

$$\Rightarrow \frac{dr}{dt} = \frac{k}{2\pi r} = \frac{k}{2\pi} \cdot \left(\frac{1}{r}\right) \quad \dots(iii)$$

Let the perimeter,

\therefore

$$P = 2\pi r$$

$$\frac{dP}{dt} = \frac{d}{dt} \cdot 2\pi r \Rightarrow \frac{dP}{dt} = 2\pi \cdot \frac{dr}{dt}$$

$$= 2\pi \cdot \frac{k}{2\pi} \cdot \frac{1}{r} = \frac{k}{r} \quad \text{[using Eq. (iii)]}$$

\Rightarrow

$$\frac{dP}{dt} \propto \frac{1}{r} \quad \text{Hence proved.}$$

Q. 3 A kite is moving horizontally at a height of 151.5 m. If the speed of kite is 10 m/s, how fast is the string being let out, when the kite is 250 m away from the boy who is flying the kite, if the height of boy is 1.5 m?

Sol. We have , height (h) = 151.5 m, speed of kite (v) = 10 m/s
Let CD be the height of kite and AB be the height of boy.

Let $DB = x$ m = EA and $AC = 250$ m

$$\therefore \frac{dx}{dt} = 10 \text{ m/s}$$

From the figure, we see that

$$EC = 151.5 - 1.5 = 150 \text{ m}$$

and

$$AE = x$$

Also,

$$AC = 250 \text{ m}$$

In right angled $\triangle CEA$,

$$AE^2 + EC^2 = AC^2$$

$$\Rightarrow x^2 + (150)^2 = y^2 \quad \dots (i)$$

$$\Rightarrow x^2 + (150)^2 = (250)^2$$

$$\Rightarrow x^2 = (250)^2 - (150)^2$$

$$= (250 + 150)(250 - 150)$$

$$= 400 \times 100$$

$$\therefore x = 20 \times 10 = 200$$

From Eq. (i), on differentiating w.r.t. t , we get

$$2x \cdot \frac{dx}{dt} + 0 = 2y \frac{dy}{dt}$$

$$\Rightarrow 2y \frac{dy}{dt} = 2x \frac{dx}{dt}$$

$$\therefore \frac{dy}{dt} = \frac{x}{y} \cdot \frac{dx}{dt}$$

$$= \frac{200}{250} \cdot 10 = 8 \text{ m/s}$$

$$\left[\therefore \frac{dx}{dt} = 10 \text{ m/s} \right]$$

So, the required rate at which the string is being let out is 8 m/s.

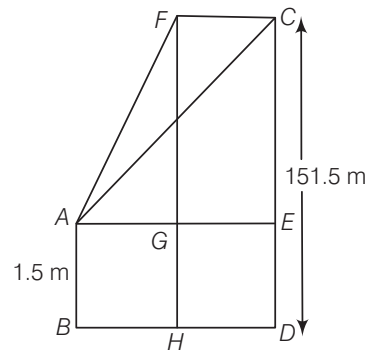

Q. 4 Two men A and B start with velocities v at the same time from the junction of two roads inclined at 45° to each other. If they travel by different roads, then find the rate at which they are being separated.

Thinking Process

By drawing figure such that men start moving at a point C , A and B are separating points, then draw perpendicular from that point C to AB to get D . Now, get the value of $\angle ACD$ in terms of x and y , then by using $\frac{dy}{dt}$ get desired result. [let $AC = BC = x$ and $AB = y$]

Sol. Let two men start from the point C with velocity v each at the same time.

Also, $\angle BCA = 45^\circ$

Since, A and B are moving with same velocity v , so they will cover same distance in same time.

Therefore, $\triangle ABC$ is an isosceles triangle with $AC = BC$.

Now, draw $CD \perp AB$.

Let at any instant t , the distance between them is AB .

Let $AC = BC = x$ and $AB = y$

In $\triangle ACD$ and $\triangle DCB$,

$$\angle CAD = \angle CBD$$

$$[\because AC = BC]$$

$$\angle CDA = \angle CDB = 90^\circ$$

$$\therefore \angle ACD = \angle DCB$$

$$\text{or } \angle ACD = \frac{1}{2} \times \angle ACB$$

$$\Rightarrow \angle ACD = \frac{1}{2} \times 45^\circ$$

$$\Rightarrow \angle ACD = \frac{\pi}{8}$$

$$\therefore \sin \frac{\pi}{8} = \frac{AD}{AC}$$

$$\Rightarrow \sin \frac{\pi}{8} = \frac{y/2}{x} \quad [\because AD = y/2]$$

$$\Rightarrow \frac{y}{2} = x \sin \frac{\pi}{8}$$

$$\Rightarrow y = 2x \cdot \sin \frac{\pi}{8}$$

Now, differentiating both sides w.r.t. t , we get

$$\frac{dy}{dt} = 2 \cdot \sin \frac{\pi}{8} \cdot \frac{dx}{dt}$$

$$= 2 \cdot \sin \frac{\pi}{8} \cdot v$$

$$[\because v = \frac{dx}{dt}]$$

$$= 2v \cdot \frac{\sqrt{2} - \sqrt{2}}{2}$$

$$[\because \sin \frac{\pi}{8} = \frac{\sqrt{2} - \sqrt{2}}{2}]$$

$$= \sqrt{2} - \sqrt{2} \text{ v unit/s}$$

which is the rate at which A and B are being separated.

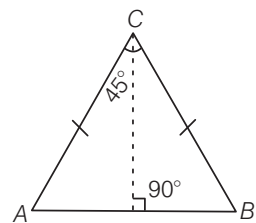

Q. 5 Find an angle θ , where $0 < \theta < \frac{\pi}{2}$, which increases twice as fast as its sine.

Sol. Let θ increases twice as fast as its sine.

$$\Rightarrow \theta = 2 \sin \theta$$

Now, on differentiating both sides w.r.t. t , we get

$$\frac{d\theta}{dt} = 2 \cdot \cos \theta \cdot \frac{d\theta}{dt} \Rightarrow 1 = 2 \cos \theta$$

$$\Rightarrow \frac{1}{2} = \cos \theta \Rightarrow \cos \theta = \cos \frac{\pi}{3}$$

$$\therefore \theta = \frac{\pi}{3}$$

So, the required angle is $\frac{\pi}{3}$.

Q. 6 Find the approximate value of $(1.999)^5$.

Sol. Let $x = 2$
and $\Delta x = -0.001$ [$\because 2 - 0.001 = 1.999$]
Let $y = x^5$

On differentiating both sides w.r.t. x , we get

$$\frac{dy}{dx} = 5x^4$$

$$\text{Now, } \Delta y = \frac{dy}{dx} \cdot \Delta x = 5x^4 \times \Delta x$$

$$= 5 \times 2^4 \times [-0.001]$$

$$= -80 \times 0.001 = -0.080$$

$$\therefore (1.999)^5 = y + \Delta y$$

$$= 2^5 + (-0.080)$$

$$= 32 - 0.080 = 31.920$$

Q. 7 Find the approximate volume of metal in a hollow spherical shell whose internal and external radii are 3 cm and 3.0005 cm, respectively.

Sol. Let internal radius = r and external radius = R

$$\therefore \text{Volume of hollow spherical shell, } V = \frac{4}{3} \pi (R^3 - r^3)$$

$$\Rightarrow V = \frac{4}{3} \pi [(3.0005)^3 - (3)^3] \quad \dots (i)$$

Now, we shall use differentiation to get approximate value of $(3.0005)^3$.

$$\text{Let } (3.0005)^3 = y + \Delta y$$

$$\text{and } x = 3, \Delta x = 0.0005$$

$$\text{Also, let } y = x^3$$

On differentiating both sides w.r.t. x , we get

$$\frac{dy}{dx} = 3x^2$$

$$\therefore \Delta y = \frac{dy}{dx} \times \Delta x = 3x^2 \times 0.0005$$

$$= 3 \times 3^2 \times 0.0005$$

$$= 27 \times 0.0005 = 0.0135$$

Also, $(3.0005)^3 = y + \Delta y$
 $= 3^3 + 0.0135 = 27.0135$
 $\therefore V = \frac{4}{3}\pi [27.0135 - 27.000]$ [using Eq. (i)]
 $= \frac{4}{3}\pi [0.0135] = 4\pi \times (0.0045)$
 $= 0.0180\pi \text{ cm}^3$

Q. 8 A man, 2 m tall, walks at the rate of $1\frac{2}{3}$ m/s towards a street light which is $5\frac{1}{3}$ m above the ground. At what rate is the tip of his shadow moving and at what rate is the length of the shadow changing when he is $3\frac{1}{3}$ m from the base of the light?

Sol. Let AB be the street light post and CD be the height of man i.e., $CD = 2$ m.

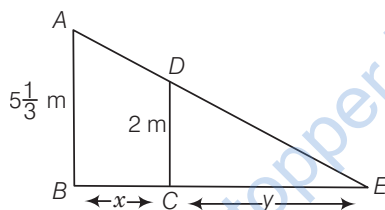

Let $BC = x$ m, $CE = y$ m and $\frac{dx}{dt} = -\frac{5}{3}$ m/s

From $\triangle ABE$ and $\triangle DCE$, we see that

$$\triangle ABE \sim \triangle DCE$$

[by AAA similarity]

$$\therefore \frac{AB}{DC} = \frac{BE}{CE} \Rightarrow \frac{16}{2} = \frac{x+y}{y}$$

$$\Rightarrow \frac{16}{6} = \frac{x+y}{y}$$

$$\Rightarrow 16y = 6x + 6y \Rightarrow 10y = 6x$$

$$\Rightarrow y = \frac{3}{5}x$$

On differentiating both sides w.r.t. t , we get

$$\frac{dy}{dt} = \frac{3}{5} \cdot \frac{dx}{dt} = \frac{3}{5} \cdot \left(-1\frac{2}{3}\right)$$

[since, man is moving towards the light post]

$$= \frac{3}{5} \cdot \left(-\frac{5}{3}\right) = -1 \text{ m/s}$$

Let $z = x + y$

Now, differentiating both sides w.r.t. t , we get

$$\frac{dz}{dt} = \frac{dx}{dt} + \frac{dy}{dt} = -\left(\frac{5}{3} + 1\right)$$

$$= -\frac{8}{3} = -2\frac{2}{3} \text{ m/s}$$

Hence, the tip of shadow is moving at the rate of $2\frac{2}{3}$ m/s towards the light source and length of the shadow is decreasing at the rate of 1 m/s.

Q. 9 A swimming pool is to be drained for cleaning. If L represents the number of litres of water in the pool t seconds after the pool has been plugged off to drain and $L = 200(10 - t)^2$. How fast is the water running out at the end of 5 s and what is the average rate at which the water flows out during the first 5 s?

Sol. Let L represents the number of litres of water in the pool t seconds after the pool has been plugged off to drain, then

$$L = 200(10 - t)^2$$

\therefore Rate at which the water is running out = $-\frac{dL}{dt}$

$$\frac{dL}{dt} = -200 \cdot 2(10 - t) \cdot (-1)$$

$$= 400(10 - t)$$

Rate at which the water is running out at the end of 5 s

$$= 400(10 - 5)$$

$$= 2000 \text{ L/s} = \text{Final rate}$$

Since, initial rate = $-\left(\frac{dL}{dt}\right)_{t=0} = 4000 \text{ L/s}$

$$\begin{aligned} \therefore \text{Average rate during 5 s} &= \frac{\text{Initial rate} + \text{Final rate}}{2} \\ &= \frac{4000 + 2000}{2} \\ &= 3000 \text{ L/s} \end{aligned}$$

Q. 10 The volume of a cube increases at a constant rate. Prove that the increase in its surface area varies inversely as the length of the side.

Sol. Let the side of a cube be x unit.

\therefore Volume of cube (V) = x^3

On differentiating both side w.r.t. t , we get

$$\frac{dV}{dt} = 3x^2 \frac{dx}{dt} = k \quad [\text{constant}]$$

$$\Rightarrow \frac{dx}{dt} = \frac{k}{3x^2} \quad \dots (i)$$

Also, surface area of cube,

$$S = 6x^2$$

On differentiating w.r.t. t , we get

$$\frac{dS}{dt} = 12x \cdot \frac{dx}{dt}$$

$$\Rightarrow \frac{dS}{dt} = 12x \cdot \frac{k}{3x^2} \quad [\text{using Eq. (i)}]$$

$$\Rightarrow \frac{dS}{dt} = \frac{12k}{3x} = 4\left(\frac{k}{x}\right)$$

$$\Rightarrow \frac{dS}{dt} \propto \frac{1}{x}$$

Hence, the surface area of the cube varies inversely as the length of the side.

Q. 11 If x and y are the sides of two squares such that $y = x - x^2$, then find the rate of change of the area of second square with respect to the area of first square.

💡 Thinking Process

First, let A_1 and A_2 be the areas of two squares and get their values in one variable and then by using dA_1/dt and dA_2/dt get the value of dA_2/dA_1

Sol. Since, x and y are the sides of two squares such that $y = x - x^2$.

\therefore Area of the first square (A_1) = x^2

and area of the second square (A_2) = $y^2 = (x - x^2)^2$

$$\therefore \frac{dA_2}{dt} = \frac{d}{dt} (x - x^2)^2 = 2(x - x^2) \left(\frac{dx}{dt} - 2x \cdot \frac{dx}{dt} \right)$$

$$= \frac{dx}{dt} (1 - 2x) 2(x - x^2)$$

and $\frac{dA_1}{dt} = \frac{d}{dt} x^2 = 2x \cdot \frac{dx}{dt}$

$$\therefore \frac{dA_2}{dA_1} = \frac{dA_2/dt}{dA_1/dt} = \frac{\frac{dx}{dt} \cdot (1 - 2x) (2x - 2x^2)}{2x \cdot \frac{dx}{dt}}$$

$$= \frac{(1 - 2x) 2x(1 - x)}{2x}$$

$$= (1 - 2x)(1 - x)$$

$$= 1 - x - 2x + 2x^2$$

$$= 2x^2 - 3x + 1$$

Q. 12 Find the condition that curves $2x = y^2$ and $2xy = k$ intersect orthogonally.

💡 Thinking Process

First, get the intersection point of the curve and then get the slopes of both the curves at that point. Then, by using $m_1 \cdot m_2 = -1$, get the required condition.

Sol. Given, equation of curves are $2x = y^2$... (i)

and $2xy = k$... (ii)

$\Rightarrow y = \frac{k}{2x}$ [from Eq. (ii)]

From Eq. (i), $2x = \left(\frac{k}{2x} \right)^2$

$\Rightarrow 8x^3 = k^2$

$\Rightarrow x^3 = \frac{1}{8} k^2$

$\Rightarrow x = \frac{1}{2} k^{2/3}$

$\therefore y = \frac{k}{2x} = \frac{k}{2 \cdot \frac{1}{2} k^{2/3}} = k^{1/3}$

Thus, we get point of intersection of curves which is $\left(\frac{1}{2} k^{2/3}, k^{1/3} \right)$.

From Eqs. (i) and (ii),

$$2 = 2y \frac{dy}{dx}$$

and

$$2 \left[x \cdot \frac{dy}{dx} + y \cdot 1 \right] = 0$$

\Rightarrow

$$\frac{dy}{dx} = \frac{1}{y}$$

and

$$\left(\frac{dy}{dx} \right) = \frac{-2y}{2x} = -\frac{y}{x}$$

\Rightarrow

$$\left(\frac{dy}{dx} \right)_{\left(\frac{1}{2}k^{2/3}, k^{1/3} \right)} = \frac{1}{k^{1/3}} \quad [\text{say } m_1]$$

and

$$\left(\frac{dy}{dx} \right)_{\left(\frac{1}{2}k^{2/3}, k^{1/3} \right)} = \frac{-k^{1/3}}{\frac{1}{2}k^{2/3}} = -2k^{-1/3} \quad [\text{say } m_2]$$

Since, the curves intersect orthogonally.

i.e.,

$$m_1 \cdot m_2 = -1$$

\Rightarrow

$$\frac{1}{k^{1/3}} \cdot (-2k^{-1/3}) = -1$$

\Rightarrow

$$-2k^{-2/3} = -1$$

\Rightarrow

$$\frac{2}{k^{2/3}} = 1$$

\Rightarrow

$$k^{2/3} = 2$$

\therefore

$$k^2 = 8$$

which is the required condition.

Q. 13 Prove that the curves $xy = 4$ and $x^2 + y^2 = 8$ touch each other.

Thinking Process

First, find the intersection points of curves and then equate the slopes of both the curves at the obtained point.

Sol. Given equation of curves are

$$xy = 4 \quad \dots(i)$$

and

$$x^2 + y^2 = 8 \quad \dots(ii)$$

\Rightarrow

$$x \cdot \frac{dy}{dx} + y = 0$$

and

$$2x + 2y \frac{dy}{dx} = 0$$

\Rightarrow

$$\frac{dy}{dx} = \frac{-y}{x}$$

and

$$\frac{dy}{dx} = \frac{-2x}{2y}$$

\Rightarrow

$$\frac{dy}{dx} = \frac{-y}{x} = m_1 \quad [\text{say}]$$

and

$$\frac{dy}{dx} = \frac{-x}{y} = m_2 \quad [\text{say}]$$

Since, both the curves should have same slope.

\therefore

$$\frac{-y}{x} = \frac{-x}{y} \Rightarrow -y^2 = -x^2$$

\Rightarrow

$$x^2 = y^2 \quad \dots(iii)$$

Using the value of x^2 in Eq. (ii), we get

$$y^2 + y^2 = 8$$

$$\Rightarrow y^2 = 4 \Rightarrow y = \pm 2$$

$$\text{For } y = 2, x = \frac{4}{2} = 2$$

$$\text{and for } y = -2, x = \frac{4}{-2} = -2$$

Thus, the required points of intersection are $(2, 2)$ and $(-2, -2)$.

$$\text{For } (2, 2), m_1 = \frac{-y}{x} = \frac{-2}{2} = -1$$

$$\text{and } m_2 = \frac{-x}{y} = \frac{-2}{2} = -1$$

$$\therefore m_1 = m_2$$

$$\text{For } (-2, -2), m_1 = \frac{-y}{x} = \frac{-(-2)}{-2} = -1$$

$$\text{and } m_2 = \frac{-x}{y} = \frac{-(-2)}{-2} = -1$$

Thus, for both the intersection points, we see that slope of both the curves are same. Hence, the curves touch each other.

Q. 14 Find the coordinates of the point on the curve $\sqrt{x} + \sqrt{y} = 4$ at which tangent is equally inclined to the axes.

Sol. We have,

$$\sqrt{x} + \sqrt{y} = 4 \quad \dots(i)$$

\Rightarrow

$$x^{1/2} + y^{1/2} = 4$$

\Rightarrow

$$\frac{1}{2} \cdot \frac{1}{x^{1/2}} + \frac{1}{2} \cdot \frac{1}{y^{1/2}} \cdot \frac{dy}{dx} = 0$$

\therefore

$$\begin{aligned} \frac{dy}{dx} &= -\frac{1}{2} \cdot x^{-1/2} \cdot 2 \cdot y^{1/2} \\ &= -\sqrt{\frac{y}{x}} \end{aligned}$$

Since, tangent is equally inclined to the axes.

$$\therefore \frac{dy}{dx} = \pm 1$$

$$\Rightarrow -\sqrt{\frac{y}{x}} = \pm 1$$

$$\Rightarrow \frac{y}{x} = 1 \Rightarrow y = x$$

From Eq. (i),

$$\sqrt{y} + \sqrt{y} = 4$$

\Rightarrow

$$2\sqrt{y} = 4$$

\Rightarrow

$$4y = 16$$

\therefore

$$y = 4 \text{ and } x = 4$$

When $y=4$, then $x = 4$

So, the required coordinates are $(4, 4)$.

Q. 15 Find the angle of intersection of the curves $y = 4 - x^2$ and $y = x^2$.

Sol. We have, $y = 4 - x^2$... (i)
 and $y = x^2$... (ii)

$\Rightarrow \frac{dy}{dx} = -2x$

and $\frac{dy}{dx} = 2x$

$\Rightarrow m_1 = -2x$

and $m_2 = 2x$

From Eqs. (i) and (ii), $x^2 = 4 - x^2$

$\Rightarrow 2x^2 = 4$

$\Rightarrow x^2 = 2$

$\Rightarrow x = \pm \sqrt{2}$

$\therefore y = x^2 = (\pm \sqrt{2})^2 = 2$

So, the points of intersection are $(\sqrt{2}, 2)$ and $(-\sqrt{2}, 2)$.

For point $(+\sqrt{2}, 2)$, $m_1 = -2x = -2 \cdot \sqrt{2} = -2\sqrt{2}$

and $m_2 = 2x = 2\sqrt{2}$

and for point $(\sqrt{2}, 2)$, $\tan \theta = \left| \frac{m_1 - m_2}{1 + m_1 m_2} \right| = \left| \frac{-2\sqrt{2} - 2\sqrt{2}}{1 - 2\sqrt{2} \cdot 2\sqrt{2}} \right| = \left| \frac{-4\sqrt{2}}{-7} \right|$

$\therefore \theta = \tan^{-1} \left(\frac{4\sqrt{2}}{7} \right)$

Q. 16 Prove that the curves $y^2 = 4x$ and $x^2 + y^2 - 6x + 1 = 0$ touch each other at the point $(1, 2)$.

Sol. We have, $y^2 = 4x$ and $x^2 + y^2 - 6x + 1 = 0$

Since, both the curves touch each other at $(1, 2)$ i.e., curves are passing through $(1, 2)$.

$\therefore 2y \cdot \frac{dy}{dx} = 4$

and $2x + 2y \frac{dy}{dx} = 6$

$\Rightarrow \frac{dy}{dx} = \frac{4}{2y}$

and $\frac{dy}{dx} = \frac{6 - 2x}{2y}$

$\Rightarrow \left(\frac{dy}{dx} \right)_{(1,2)} = \frac{4}{4} = 1$

and $\left(\frac{dy}{dx} \right)_{(1,2)} = \frac{6 - 2 \cdot 1}{2 \cdot 2} = \frac{4}{4} = 1$

$\Rightarrow m_1 = 1$ and $m_2 = 1$

Thus, we see that slope of both the curves are equal to each other i.e., $m_1 = m_2 = 1$ at the point $(1, 2)$.

Hence, both the curves touch each other.

Q. 17 Find the equation of the normal lines to the curve $3x^2 - y^2 = 8$ which are parallel to the line $x + 3y = 4$.

Sol. Given equation of the curve is

$$3x^2 - y^2 = 8 \quad \dots(i)$$

On differentiating both sides w.r.t. x , we get

$$6x - 2y \frac{dy}{dx} = 0$$

$$\Rightarrow \frac{dy}{dx} = \frac{6x}{2y} = \frac{3x}{y}$$

$$\Rightarrow m_1 = \frac{3x}{y} \quad \text{[say]}$$

$$\text{and slope of normal } (m_2) = \frac{-1}{m_1} = \frac{-y}{3x} \quad \dots(ii)$$

Since, slope of normal to the curve should be equal to the slope of line $x + 3y = 4$, which is parallel to curve.

$$\text{For line, } y = \frac{4-x}{3} = \frac{-x}{3} + \frac{4}{3}$$

$$\Rightarrow \text{Slope of the line } (m_3) = \frac{-1}{3}$$

$$\therefore m_2 = m_3$$

$$\Rightarrow \frac{-y}{3x} = \frac{-1}{3}$$

$$\Rightarrow -3y = -3x$$

$$\Rightarrow y = x \quad \dots(iii)$$

On substituting the value of y in Eq. (i), we get

$$3x^2 - x^2 = 8$$

$$\Rightarrow x^2 = 4$$

$$\Rightarrow x = \pm 2$$

$$\text{For } x = 2, \quad y = 2 \quad \text{[using Eq. (iii)]}$$

$$\text{and for } x = -2, \quad y = -2 \quad \text{[using Eq. (iii)]}$$

Thus, the points at which normal to the curve are parallel to the line $x + 3y = 4$ are $(2, 2)$ and $(-2, -2)$.

Required equations of normal are

$$y - 2 = m_2(x - 2) \quad \text{and} \quad y + 2 = m_2(x + 2)$$

$$\Rightarrow y - 2 = \frac{-2}{6}(x - 2) \quad \text{and} \quad y + 2 = \frac{-2}{6}(x + 2)$$

$$\Rightarrow 3y - 6 = -x + 2 \quad \text{and} \quad 3y + 6 = -x - 2$$

$$\Rightarrow 3y + x = +8 \quad \text{and} \quad 3y + x = -8$$

So, the required equations are $3y + x = \pm 8$.

Q. 18 At what points on the curve $x^2 + y^2 - 2x - 4y + 1 = 0$, the tangents are parallel to the Y -axis?

Sol. Given, equation of curve which is

$$x^2 + y^2 - 2x - 4y + 1 = 0 \quad \dots(i)$$

$$\Rightarrow 2x + 2y \frac{dy}{dx} - 2 - 4 \frac{dy}{dx} = 0$$

$$\Rightarrow \frac{dy}{dx}(2y - 4) = 2 - 2x$$

$$\Rightarrow \frac{dy}{dx} = \frac{2(1-x)}{2(y-2)}$$

Since, the tangents are parallel to the Y-axis *i.e.*, $\tan \theta = \tan 90^\circ = \frac{dy}{dx}$.

$$\therefore \frac{1-x}{y-2} = 0$$

$$\Rightarrow y - 2 = 0$$

$$\Rightarrow y = 2$$

For $y = 2$ from Eq. (i), we get

$$x^2 + 2^2 - 2x - 4 \times 2 + 1 = 0$$

$$\Rightarrow x^2 - 2x - 3 = 0$$

$$\Rightarrow x^2 - 3x + x - 3 = 0$$

$$\Rightarrow x(x-3) + 1(x-3) = 0$$

$$\Rightarrow (x+1)(x-3) = 0$$

$$\therefore x = -1, x = 3$$

So, the required points are $(-1, 2)$ and $(3, 2)$.

Q. 19 Show that the line $\frac{x}{a} + \frac{y}{b} = 1$, touches the curve $y = b \cdot e^{-x/a}$ at the point, where the curve intersects the axis of Y.

Sol. We have the equation of line given by $\frac{x}{a} + \frac{y}{b} = 1$, which touches the curve $y = b \cdot e^{-x/a}$ at the point, where the curve intersects the axis of Y *i.e.*, $x = 0$.

$$\therefore y = b \cdot e^{-0/a} = b \quad [\because e^0 = 1]$$

So, the point of intersection of the curve with Y-axis is $(0, b)$.

Now, slope of the given line at $(0, b)$ is given by

$$\frac{1}{a} \cdot 1 + \frac{1}{b} \cdot \frac{dy}{dx} = 0$$

$$\Rightarrow \frac{dy}{dx} = \frac{-1}{a} \cdot b$$

$$\Rightarrow \frac{dy}{dx} = -\frac{1}{a} \cdot b = \frac{-b}{a} = m_1 \quad [\text{say}]$$

Also, the slope of the curve at $(0, b)$ is

$$\frac{dy}{dx} = b \cdot e^{-x/a} \cdot \frac{-1}{a}$$

$$\frac{dy}{dx} = \frac{-b}{a} e^{-x/a}$$

$$\left(\frac{dy}{dx}\right)_{(0, b)} = \frac{-b}{a} e^{-0} = \frac{-b}{a} = m_2 \quad [\text{say}]$$

Since, $m_1 = m_2 = \frac{-b}{a}$

Hence, the line touches the curve at the point, where the curve intersects the axis of Y.

Q. 20 Show that $f(x) = 2x + \cot^{-1} x + \log(\sqrt{1+x^2} - x)$ is increasing in R .

Thinking Process

If $f'(x) \geq 0$, then we can say that $f(x)$ is increasing function. Use this condition to show the desired result.

Sol. We have, $f(x) = 2x + \cot^{-1} x + \log(\sqrt{1+x^2} - x)$

$$\begin{aligned} \therefore f'(x) &= 2 + \left(\frac{-1}{1+x^2} \right) + \frac{1}{(\sqrt{1+x^2} - x)} \left(\frac{1}{2\sqrt{1+x^2}} \cdot 2x - 1 \right) \\ &= 2 - \frac{1}{1+x^2} + \frac{1}{(\sqrt{1+x^2} - x)} \cdot \frac{(x - \sqrt{1+x^2})}{\sqrt{1+x^2}} \\ &= 2 - \frac{1}{1+x^2} - \frac{1}{\sqrt{1+x^2}} \\ &= \frac{2 + 2x^2 - 1 - \sqrt{1+x^2}}{1+x^2} = \frac{1 + 2x^2 - \sqrt{1+x^2}}{1+x^2} \end{aligned}$$

For increasing function, $f'(x) \geq 0$

$$\Rightarrow \frac{1 + 2x^2 - \sqrt{1+x^2}}{1+x^2} \geq 0$$

$$\Rightarrow 1 + 2x^2 \geq \sqrt{1+x^2}$$

$$\Rightarrow (1 + 2x^2)^2 \geq 1 + x^2$$

$$\Rightarrow 1 + 4x^4 + 4x^2 \geq 1 + x^2$$

$$\Rightarrow 4x^4 + 3x^2 \geq 0$$

$$\Rightarrow x^2(4x^2 + 3) \geq 0$$

which is true for any real value of x .

Hence, $f(x)$ is increasing in R .

Q. 21 Show that for $a \geq 1$, $f(x) = \sqrt{3} \sin x - \cos x - 2ax + b$ is decreasing in R .

Thinking Process

If $f'(x) \leq 0$, then we can say that $f(x)$ is a decreasing function. So, use this condition to show the result.

Sol. We have, $a \geq 1$, $f(x) = \sqrt{3} \sin x - \cos x - 2ax + b$

$$\begin{aligned} \therefore f'(x) &= \sqrt{3} \cos x - (-\sin x) - 2a \\ &= \sqrt{3} \cos x + \sin x - 2a \\ &= 2 \left[\frac{\sqrt{3}}{2} \cdot \cos x + \frac{1}{2} \cdot \sin x \right] - 2a \\ &= 2 \left[\cos \frac{\pi}{6} \cdot \cos x + \sin \frac{\pi}{6} \cdot \sin x \right] - 2a \\ &= 2 \left(\cos \frac{\pi}{6} - x \right) - 2a \\ & \qquad \qquad \qquad [\because \cos(A - B) = \cos A \cdot \cos B + \sin A \cdot \sin B] \\ &= 2 \left[\left(\cos \frac{\pi}{6} - x \right) - a \right] \end{aligned}$$

We know that,
and

$$\cos x \in [-1, 1]$$

$$a \geq 1$$

So,

$$2 \left[\cos \left(\frac{\pi}{6} - x \right) - a \right] \leq 0$$

\therefore

$$f'(x) \leq 0$$

Hence, $f(x)$ is a decreasing function in R .

Q. 22 Show that $f(x) = \tan^{-1}(\sin x + \cos x)$ is an increasing function in $\left(0, \frac{\pi}{4}\right)$.

Sol. We have,

$$f(x) = \tan^{-1}(\sin x + \cos x)$$

\therefore

$$f'(x) = \frac{1}{1 + (\sin x + \cos x)^2} \cdot (\cos x - \sin x)$$

$$= \frac{1}{1 + \sin^2 x + \cos^2 x + 2\sin x \cdot \cos x} (\cos x - \sin x)$$

$$= \frac{1}{(2 + \sin 2x)} (\cos x - \sin x)$$

$$[\because \sin 2x = 2\sin x \cos x \text{ and } \sin^2 x + \cos^2 x = 1]$$

For $f'(x) \geq 0$,

$$\frac{1}{(2 + \sin 2x)} \cdot (\cos x - \sin x) \geq 0$$

\Rightarrow

$$\cos x - \sin x \geq 0$$

$$\left[\because (2 + \sin 2x) \geq 0 \text{ in } \left(0, \frac{\pi}{4}\right) \right]$$

\Rightarrow

$$\cos x \geq \sin x$$

which is true, if $x \in \left(0, \frac{\pi}{4}\right)$.

Hence, $f(x)$ is an increasing function in $\left(0, \frac{\pi}{4}\right)$.

Q. 23 At what point, the slope of the curve $y = -x^3 + 3x^2 + 9x - 27$ is maximum? Also, find the maximum slope.

Sol. We have,

$$y = -x^3 + 3x^2 + 9x - 27$$

\therefore

$$\frac{dy}{dx} = -3x^2 + 6x + 9 = \text{Slope of tangent to the curve}$$

Now,

$$\frac{d^2y}{dx^2} = -6x + 6$$

$$\text{For } \frac{d}{dx} \left(\frac{dy}{dx} \right) = 0,$$

$$-6x + 6 = 0$$

\Rightarrow

$$x = \frac{-6}{-6} = 1$$

\therefore

$$\frac{d}{dx} \left(\frac{d^2y}{dx^2} \right) = -6 < 0$$

So, the slope of tangent to the curve is maximum, when $x = 1$.

$$\text{For } x = 1, \quad \left(\frac{dy}{dx} \right)_{(x=1)} = -3 \cdot 1^2 + 6 \cdot 1 + 9 = 12,$$

which is maximum slope.

Also, for

$$\begin{aligned}x = 1, y &= -1^3 + 3 \cdot 1^2 + 9 \cdot 1 - 27 \\ &= -1 + 3 + 9 - 27 \\ &= -16\end{aligned}$$

So, the required point is $(1, -16)$.

Q. 24 Prove that $f(x) = \sin x + \sqrt{3} \cos x$ has maximum value at $x = \frac{\pi}{6}$.

Sol. We have,

$$\begin{aligned}f(x) &= \sin x + \sqrt{3} \cos x \\ \therefore f'(x) &= \cos x + \sqrt{3}(-\sin x) \\ &= \cos x - \sqrt{3} \sin x\end{aligned}$$

For $f'(x) = 0$,

$$\cos x = \sqrt{3} \sin x$$

$$\Rightarrow \tan x = \frac{1}{\sqrt{3}} = \tan \frac{\pi}{6}$$

$$\Rightarrow x = \frac{\pi}{6}$$

Again, differentiating $f'(x)$, we get

$$\begin{aligned}f''(x) &= -\sin x - \sqrt{3} \cos x \\ \text{At } x = \frac{\pi}{6}, f''(x) &= -\sin \frac{\pi}{6} - \sqrt{3} \cos \frac{\pi}{6} \\ &= -\frac{1}{2} - \sqrt{3} \cdot \frac{\sqrt{3}}{2} \\ &= -\frac{1}{2} - \frac{3}{2} = -2 < 0\end{aligned}$$

Hence, at $x = \frac{\pi}{6}$, $f(x)$ has maximum value at $\frac{\pi}{6}$ is the point of local maxima.

Long Answer Type Questions

Q. 25 If the sum of lengths of the hypotenuse and a side of a right angled triangle is given, then show that the area of triangle is maximum, when the angle between them is $\frac{\pi}{3}$.

Sol. Let ABC be a triangle with $AC = h$, $AB = x$ and $BC = y$.
Also, $\angle CAB = \theta$
Let $h + x = k$...(i)

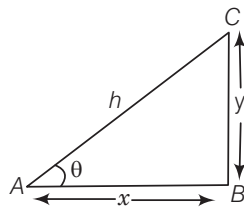

$$\begin{aligned}\therefore \cos \theta &= \frac{x}{h} \\ \Rightarrow x &= h \cos \theta \\ \Rightarrow h + h \cos \theta &= k\end{aligned}$$

[using Eq. (i)]

$$\Rightarrow h(1 + \cos \theta) = k$$

$$\Rightarrow h = \frac{k}{1 + \cos \theta} \quad \dots \text{(ii)}$$

Also,

$$\text{area of } \Delta ABC = \frac{1}{2}(AB \cdot BC)$$

$$A = \frac{1}{2} \cdot x \cdot y$$

$$= \frac{1}{2} h \cos \theta \cdot h \sin \theta \quad \left[\because \sin \theta = \frac{y}{h} \right]$$

$$= \frac{1}{2} h^2 \sin \theta \cdot \cos \theta$$

$$= \frac{2h^2}{4} \sin \theta \cdot \cos \theta$$

$$= \frac{1}{4} h^2 \sin 2\theta \quad \dots \text{(iii)}$$

Since,

$$h = \frac{k}{1 + \cos \theta}$$

$$\therefore A = \frac{1}{4} \left(\frac{k}{1 + \cos \theta} \right)^2 \cdot \sin 2\theta$$

$$\Rightarrow A = \frac{k^2}{4} \cdot \frac{\sin 2\theta}{(1 + \cos \theta)^2} \quad \dots \text{(iv)}$$

$$\therefore \frac{dA}{d\theta} = \frac{k^2}{4} \left[\frac{(1 + \cos \theta)^2 \cdot \cos 2\theta \cdot 2 - \sin 2\theta \cdot 2(1 + \cos \theta) \cdot (0 - \sin \theta)}{(1 + \cos \theta)^4} \right]$$

$$= \frac{k^2}{4} \left\{ \frac{2(1 + \cos \theta)[(1 + \cos \theta) \cdot \cos 2\theta + \sin 2\theta (\sin \theta)]}{(1 + \cos \theta)^4} \right\}$$

$$= \frac{k^2}{4} \cdot \frac{2}{(1 + \cos \theta)^3} [(1 + \cos \theta) \cdot \cos 2\theta + 2 \sin^2 \theta \cdot \cos \theta]$$

$$= \frac{k^2}{2(1 + \cos \theta)^3} [(1 + \cos \theta)(1 - 2 \sin^2 \theta) + 2 \sin^2 \theta \cdot \cos \theta]$$

$$= \frac{k^2}{2(1 + \cos \theta)^3} [1 + \cos \theta - 2 \sin^2 \theta - 2 \sin^2 \theta \cdot \cos \theta + 2 \sin^2 \theta \cdot \cos \theta]$$

$$= \frac{k^2}{2(1 + \cos \theta)^3} [(1 + \cos \theta) - 2 \sin^2 \theta]$$

$$= \frac{k^2}{2(1 + \cos \theta)^3} [1 + \cos \theta - 2 + 2 \cos^2 \theta]$$

$$= \frac{k^2}{2(1 + \cos \theta)^3} (2 \cos^2 \theta + \cos \theta - 1) \quad \dots \text{(v)}$$

For $\frac{dA}{d\theta} = 0$,

$$\frac{k^2}{2(1 + \cos \theta)^3} (2 \cos^2 \theta + \cos \theta - 1) = 0$$

$$\Rightarrow 2 \cos^2 \theta + \cos \theta - 1 = 0$$

$$\Rightarrow 2 \cos^2 \theta + 2 \cos \theta - \cos \theta - 1 = 0$$

$$\Rightarrow 2 \cos \theta (\cos \theta + 1) - 1(\cos \theta + 1) = 0$$

$$\Rightarrow (2 \cos \theta - 1)(\cos \theta + 1) = 0$$

$$\begin{aligned} \Rightarrow \quad & \cos \theta = \frac{1}{2} \text{ or } \cos \theta = -1 \\ \Rightarrow \quad & \theta = \frac{\pi}{3} \quad \text{[possible]} \\ \text{or} \quad & \theta = 2n\pi \pm \pi \quad \text{[not possible]} \\ \therefore \quad & \theta = \frac{\pi}{3} \end{aligned}$$

Again, differentiating w.r.t. θ in Eq. (v), we get

$$\begin{aligned} \frac{d}{d\theta} \left(\frac{dA}{d\theta} \right) &= \frac{d}{d\theta} \left[\frac{k^2}{2(1 + \cos \theta)^3} (2\cos^2 \theta + \cos \theta - 1) \right] \\ \therefore \quad \frac{d^2 A}{d\theta^2} &= \frac{d}{d\theta} \left[\frac{k^2 (2\cos \theta - 1)(1 + \cos \theta)}{2(1 + \cos \theta)^3} \right] = \frac{d}{d\theta} \left[\frac{k^2 (2\cos \theta - 1)}{2(1 + \cos \theta)^2} \right] \\ &= \frac{k^2}{2} \left[\frac{(1 + \cos \theta)^2 \cdot (-2\sin \theta) - 2(1 + \cos \theta) \cdot (-\sin \theta)(2\cos \theta - 1)}{(1 + \cos \theta)^4} \right] \\ &= \frac{k^2}{2} \left[\frac{(1 + \cos \theta) \cdot [1 + \cos \theta](-2\sin \theta) + 2\sin \theta (2\cos \theta - 1)}{(1 + \cos \theta)^4} \right] \\ &= \frac{k^2}{2} \left[\frac{-2\sin \theta - 2\sin \theta \cdot \cos \theta + 4\sin \theta \cdot \cos \theta - 2\sin \theta}{(1 + \cos \theta)^3} \right] \\ &= \frac{k^2}{2} \left[\frac{-4\sin \theta - \sin 2\theta + 2\sin 2\theta}{(1 + \cos \theta)^3} \right] = \frac{k^2}{2} \left[\frac{\sin 2\theta - 4\sin \theta}{(1 + \cos \theta)^3} \right] \\ \therefore \quad \left(\frac{d^2 A}{d\theta^2} \right)_{\text{at } \theta = \frac{\pi}{3}} &= \frac{k^2}{2} \left[\frac{\sin \frac{2\pi}{3} - 4\sin \frac{\pi}{3}}{\left(1 + \cos \frac{\pi}{3}\right)^3} \right] = \frac{k^2}{2} \left[\frac{\frac{\sqrt{3}}{2} - \frac{4\sqrt{3}}{2}}{\left(1 + \frac{1}{2}\right)^3} \right] \\ &= \frac{k^2}{2} \left[\frac{-3\sqrt{3} \cdot 8}{2 \cdot 27} \right] = -k^2 \left(\frac{2\sqrt{3}}{9} \right) \end{aligned}$$

which is less than zero.

Hence, area of the right angled triangle is maximum, when the angle between them is $\frac{\pi}{3}$.

Q. 26 Find the points of local maxima, local minima and the points of inflection of the function $f(x) = x^5 - 5x^4 + 5x^3 - 1$. Also, find the corresponding local maximum and local minimum values.

Sol. Given that, $f(x) = x^5 - 5x^4 + 5x^3 - 1$
On differentiating w.r.t. x , we get

$$f'(x) = 5x^4 - 20x^3 + 15x^2$$

For maxima or minima, $f'(x) = 0$

$$\Rightarrow 5x^4 - 20x^3 + 15x^2 = 0$$

$$\Rightarrow 5x^2(x^2 - 4x + 3) = 0$$

$$\Rightarrow 5x^2(x^2 - 3x - x + 3) = 0$$

$$\Rightarrow 5x^2[x(x - 3) - 1(x - 3)] = 0$$

$$\Rightarrow 5x^2[(x - 1)(x - 3)] = 0$$

$$\therefore x = 0, 1, 3$$

Sign scheme for $\frac{dy}{dx} = 5x^2(x-1)(x-3)$

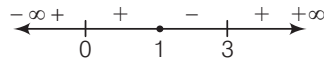

So, y has maximum value at $x = 1$ and minimum value at $x = 3$.

At $x = 0$, y has neither maximum nor minimum value.

\therefore Maximum value of $y = 1 - 5 + 5 - 1 = 0$

and minimum value $= (3)^5 - 5(3)^4 + 5(3)^3 - 1$
 $= 243 - 81 \times 5 - 27 \times 5 - 1 = -298$

Q. 27 A telephone company in a town has 500 subscribers on its list and collects fixed charges of ₹ 300 per subscriber per year. The company proposes to increase the annual subscription and it is believed that for every increase of ₹ 1 per one subscriber will discontinue the service. Find what increase will bring maximum profit?

Sol. Consider that company increases the annual subscription by ₹ x .

So, x subscribers will discontinue the service.

\therefore Total revenue of company after the increment is given by

$$\begin{aligned} R(x) &= (500 - x)(300 + x) \\ &= 15 \times 10^4 + 500x - 300x - x^2 \\ &= -x^2 + 200x + 150000 \end{aligned}$$

On differentiating both sides w.r.t. x , we get

$$R'(x) = -2x + 200$$

Now,

$$R'(x) = 0$$

$$\Rightarrow 2x = 200 \Rightarrow x = 100$$

$$\therefore R''(x) = -2 < 0$$

So, $R(x)$ is maximum when $x = 100$.

Hence, the company should increase the subscription fee by ₹ 100, so that it has maximum profit.

Q. 28 If the straight line $x \cos \alpha + y \sin \alpha = p$ touches the curve

$$\frac{x^2}{a^2} + \frac{y^2}{b^2} = 1, \text{ then prove that } a^2 \cos^2 \alpha + b^2 \sin^2 \alpha = p^2.$$

Sol. Given, line is $x \cos \alpha + y \sin \alpha = p$... (i)

and curve is $\frac{x^2}{a^2} + \frac{y^2}{b^2} = 1$

$$\Rightarrow b^2 x^2 + a^2 y^2 = a^2 b^2 \quad \dots \text{(ii)}$$

Now, differentiating Eq. (ii) w.r.t. x , we get

$$b^2 \cdot 2x + a^2 \cdot 2y \cdot \frac{dy}{dx} = 0$$

$$\Rightarrow \frac{dy}{dx} = \frac{-2b^2 x}{2a^2 y} = \frac{-xb^2}{ya^2} \quad \dots \text{(iii)}$$

From Eq. (i), $y \sin \alpha = p - x \cos \alpha$

$$\Rightarrow y = -x \cot \alpha + \frac{p}{\sin \alpha}$$

Thus, slope of the line is $(-\cot \alpha)$.

So, the given equation of line will be tangent to the Eq. (ii), if $\left(-\frac{x}{y} \cdot \frac{b^2}{a^2}\right) = (-\cot \alpha)$

$$\Rightarrow \frac{x}{a^2 \cos \alpha} = \frac{y}{b^2 \sin \alpha} = k \quad [\text{say}]$$

$$\Rightarrow x = ka^2 \cos \alpha$$

$$\text{and } y = b^2 k \sin \alpha$$

So, the line $x \cos \alpha + y \sin \alpha = p$ will touch the curve $\frac{x^2}{a^2} + \frac{y^2}{b^2}$ at point $(ka^2 \cos \alpha, kb^2 \sin \alpha)$.

$$\text{From Eq. (i), } ka^2 \cos^2 \alpha + kb^2 \sin^2 \alpha = p$$

$$\Rightarrow a^2 \cos^2 \alpha + b^2 \sin^2 \alpha = \frac{p}{k}$$

$$\Rightarrow (a^2 \cos^2 \alpha + b^2 \sin^2 \alpha)^2 = \frac{p^2}{k^2} \quad \dots(\text{iv})$$

$$\text{From Eq. (ii), } b^2 k^2 a^4 \cos^2 \alpha + a^2 k^2 b^4 \sin^2 \alpha = a^2 b^2$$

$$\Rightarrow k^2 (a^2 \cos^2 \alpha + b^2 \sin^2 \alpha) = 1$$

$$\Rightarrow (a^2 \cos^2 \alpha + b^2 \sin^2 \alpha) = \frac{1}{k^2} \quad \dots(\text{v})$$

On dividing Eq. (iv) by Eq. (v), we get

$$a^2 \cos^2 \alpha + b^2 \sin^2 \alpha = p^2$$

Hence proved.

Alternate Method

We know that, if a line $y = mx + c$ touches ellipse $\frac{x^2}{a^2} + \frac{y^2}{b^2} = 1$, then

the required condition is $c^2 = a^2 m^2 + b^2$

Here, given equation of the line is

$$x \cos \alpha + y \sin \alpha = p$$

$$\Rightarrow y = \frac{p - x \cos \alpha}{\sin \alpha}$$

$$= -x \cot \alpha + \frac{p}{\sin \alpha}$$

$$\Rightarrow c = \frac{p}{\sin \alpha}$$

$$\text{and } m = -\cot \alpha$$

$$\therefore \left(\frac{p}{\sin \alpha}\right)^2 = a^2 (-\cot \alpha)^2 + b^2$$

$$\Rightarrow \frac{p^2}{\sin^2 \alpha} = a^2 \frac{\cos^2 \alpha}{\sin^2 \alpha} + b^2$$

$$\Rightarrow p^2 = a^2 \cos^2 \alpha + b^2 \sin^2 \alpha$$

Hence proved.

Q. 29 If an open box with square base is to be made of a given quantity of card board of area c^2 , then show that the maximum volume of the box is $\frac{c^3}{6\sqrt{3}}$ cu units.

Thinking Process

First, let the sides of box in x and y then find $\frac{dV}{dx}$ in terms c and x . Also, for $\frac{dV}{dx}=0$ get the value of x and if $\frac{d^2V}{dx^2} < 0$ at the value of x , then by putting that value of x in the equation of V , get the desired result.

Sol. Let the length of side of the square base of open box be x units and its height be y units.

\therefore Area of the metal used = $x^2 + 4xy$

$\Rightarrow x^2 + 4xy = c^2$ [given]

$\Rightarrow y = \frac{c^2 - x^2}{4x}$... (i)

Now, volume of the box (V) = x^2y

$\Rightarrow V = x^2 \cdot \left(\frac{c^2 - x^2}{4x}\right)$
 $= \frac{1}{4}x(c^2 - x^2)$
 $= \frac{1}{4}(c^2x - x^3)$

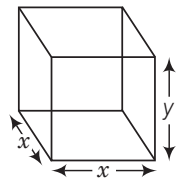

On differentiating both sides w.r.t. x , we get

$\frac{dV}{dx} = \frac{1}{4}(c^2 - 3x^2)$... (ii)

Now, $\frac{dV}{dx} = 0 \Rightarrow c^2 = 3x^2$

$\Rightarrow x^2 = \frac{c^2}{3}$

$\Rightarrow x = \frac{c}{\sqrt{3}}$ [using positive sign]

Again, differentiating Eq. (ii) w.r.t. x , we get

$\frac{d^2V}{dx^2} = \frac{1}{4}(-6x) = \frac{-3}{2}x < 0$

$\therefore \left(\frac{d^2V}{dx^2}\right)_{\text{at } x = \frac{c}{\sqrt{3}}} = -\frac{3}{2} \cdot \left(\frac{c}{\sqrt{3}}\right) < 0$

Thus, we see that volume (V) is maximum at $x = \frac{c}{\sqrt{3}}$.

\therefore Maximum volume of the box, $(V)_{x = \frac{c}{\sqrt{3}}} = \frac{1}{4} \left(c^2 \cdot \frac{c}{\sqrt{3}} - \frac{c^3}{3\sqrt{3}} \right)$
 $= \frac{1}{4} \cdot \frac{(3c^3 - c^3)}{3\sqrt{3}} = \frac{1}{4} \cdot \frac{2c^3}{3\sqrt{3}}$
 $= \frac{c^3}{6\sqrt{3}}$ cu units

Q. 30 Find the dimensions of the rectangle of perimeter 36 cm which will sweep out a volume as large as possible, when revolved about one of its sides. Also, find the maximum volume.

Sol. Let breadth and length of the rectangle be x and y , respectively.

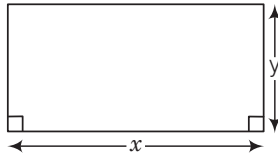

$$\begin{aligned} \therefore & \text{Perimeter of the rectangle} = 36 \text{ cm} \\ \Rightarrow & 2x + 2y = 36 \\ \Rightarrow & x + y = 18 \\ \Rightarrow & y = 18 - x \end{aligned} \quad \dots (i)$$

Let the rectangle is being revolved about its length y .

Then, volume (V) of resultant cylinder = $\pi x^2 \cdot y$

$$\begin{aligned} \Rightarrow & V = \pi x^2 \cdot (18 - x) \quad [\because V = \pi r^2 h] \text{ [using Eq. (i)]} \\ & = 18\pi x^2 - \pi x^3 = \pi [18x^2 - x^3] \end{aligned}$$

On differentiating both sides w.r.t. x , we get

$$\frac{dV}{dx} = \pi (36x - 3x^2)$$

Now,

$$\frac{dV}{dx} = 0$$

$$\Rightarrow 36x = 3x^2$$

$$\Rightarrow 3x^2 - 36x = 0$$

$$\Rightarrow 3(x^2 - 12x) = 0$$

$$\Rightarrow 3x(x - 12) = 0$$

$$\Rightarrow x = 0, x = 12$$

$$\therefore x = 12 \quad [\because, x \neq 0]$$

Again, differentiating w.r.t. x , we get

$$\frac{d^2V}{dx^2} = \pi (36 - 6x)$$

$$\Rightarrow \left(\frac{d^2V}{dx^2} \right)_{x=12} = \pi (36 - 6 \times 12) = -36\pi < 0$$

At $x = 12$, volume of the resultant cylinder is the maximum.

So, the dimensions of rectangle are 12 cm and 6 cm, respectively.

[using Eq. (i)]

\therefore Maximum volume of resultant cylinder,

$$\begin{aligned} (V)_{x=12} &= \pi [18 \cdot (12)^2 - (12)^3] \\ &= \pi [12^2 (18 - 12)] \\ &= \pi \times 144 \times 6 \\ &= 864 \pi \text{ cm}^3 \end{aligned}$$

Q. 31 If the sum of the surface areas of cube and a sphere is constant, what is the ratio of an edge of the cube to the diameter of the sphere, when the sum of their volumes is minimum?

Sol. Let length of one edge of cube be x units and radius of sphere be r units.

$$\therefore \text{Surface area of cube} = 6x^2$$

$$\text{and surface area of sphere} = 4\pi r^2$$

$$\text{Also, } 6x^2 + 4\pi r^2 = k \quad [\text{constant, given}]$$

$$\Rightarrow 6x^2 = k - 4\pi r^2$$

$$\Rightarrow x^2 = \frac{k - 4\pi r^2}{6}$$

$$\Rightarrow x = \left[\frac{k - 4\pi r^2}{6} \right]^{1/2} \quad \dots (i)$$

$$\text{Now, volume of cube} = x^3$$

$$\text{and volume of sphere} = \frac{4}{3}\pi r^3$$

Let sum of volume of the cube and volume of the sphere be given by

$$S = x^3 + \frac{4}{3}\pi r^3 = \left[\frac{k - 4\pi r^2}{6} \right]^{3/2} + \frac{4}{3}\pi r^3$$

On differentiating both sides w.r.t. r , we get

$$\frac{dS}{dr} = \frac{3}{2} \left[\frac{k - 4\pi r^2}{6} \right]^{1/2} \cdot \left(\frac{-8\pi r}{6} \right) + \frac{12}{3}\pi r^2$$

$$= -2\pi r \left[\frac{k - 4\pi r^2}{6} \right]^{1/2} + 4\pi r^2 \quad \dots (ii)$$

$$= -2\pi r \left[\left\{ \frac{k - 4\pi r^2}{6} \right\}^{1/2} - 2r \right]$$

$$\text{Now, } \frac{dS}{dr} = 0$$

$$\Rightarrow r = 0 \text{ or } 2r = \left(\frac{k - 4\pi r^2}{6} \right)^{1/2}$$

$$\Rightarrow 4r^2 = \frac{k - 4\pi r^2}{6} \Rightarrow 24r^2 = k - 4\pi r^2$$

$$\Rightarrow 24r^2 + 4\pi r^2 = k \Rightarrow r^2 [24 + 4\pi] = k$$

$$\therefore r = 0 \text{ or } r = \sqrt{\frac{k}{24 + 4\pi}} = \frac{1}{2} \sqrt{\frac{k}{6 + \pi}}$$

$$\text{We know that, } r \neq 0$$

$$\therefore r = \frac{1}{2} \sqrt{\frac{k}{6 + \pi}}$$

Again, differentiating w.r.t. r in Eq. (ii), we get

$$\frac{d^2S}{dr^2} = \frac{d}{dr} \left[-2\pi r \left\{ \left(\frac{k - 4\pi r^2}{6} \right)^{1/2} + 4\pi r^2 \right\} \right]$$

$$\begin{aligned}
&= -2\pi \left[r \cdot \frac{1}{2} \left(\frac{k - 4\pi r^2}{6} \right)^{-1/2} \cdot \left(\frac{-8\pi r}{6} \right) + \left(\frac{k - 4\pi r^2}{6} \right)^{1/2} \cdot 1 \right] + 4\pi \cdot 2r \\
&= -2\pi \left[r \cdot \frac{1}{2\sqrt{\frac{k - 4\pi r^2}{6}}} \cdot \left(\frac{-8\pi r}{6} \right) + \sqrt{\frac{k - 4\pi r^2}{6}} \right] + 8\pi r \\
&= -2\pi \left[\frac{-8\pi r^2 + 12 \left(k - \frac{4\pi r^2}{6} \right)}{12\sqrt{\frac{k - 4\pi r^2}{6}}} \right] + 8\pi r \\
&= -2\pi \left[\frac{-48\pi r^2 + 72k - 48\pi r^2}{72\sqrt{\frac{k - 4\pi r^2}{6}}} \right] + 8\pi r = -2\pi \left[\frac{-96\pi r^2 + 72k}{72\sqrt{\frac{k - 4\pi r^2}{6}}} \right] + 8\pi r > 0
\end{aligned}$$

For $r = \frac{1}{2} \sqrt{\frac{k}{6 + \pi}}$, then the sum of their volume is minimum.

$$\begin{aligned}
\text{For } r = \frac{1}{2} \sqrt{\frac{k}{6 + \pi}}, \quad x &= \left[\frac{k - 4\pi \cdot \frac{1}{4} \frac{k}{6 + \pi}}{6} \right]^{1/2} \\
&= \left[\frac{(6 + \pi)k - \pi k}{6(6 + \pi)} \right]^{1/2} = \left[\frac{k}{6 + \pi} \right]^{1/2} = 2r
\end{aligned}$$

Since, the sum of their volume is minimum when $x = 2r$.

Hence, the ratio of an edge of cube to the diameter of the sphere is 1:1.

Q. 32 If AB is a diameter of a circle and C is any point on the circle, then show that the area of $\triangle ABC$ is maximum, when it is isosceles.

Sol. We have,

$$AB = 2r$$

and

$$\angle ACB = 90^\circ \quad [\text{since, angle in the semi-circle is always } 90^\circ]$$

Let

$$AC = x \text{ and } BC = y$$

\therefore

$$(2r)^2 = x^2 + y^2$$

\Rightarrow

$$y^2 = 4r^2 - x^2$$

\Rightarrow

$$y = \sqrt{4r^2 - x^2} \quad \dots (i)$$

Now,

$$\text{area of } \triangle ABC, A = \frac{1}{2} \times x \times y$$

$$= \frac{1}{2} \times x \times (4r^2 - x^2)^{1/2} \quad [\text{using Eq. (i)}]$$

Now, differentiating both sides w.r.t. x , we get

$$\frac{dA}{dx} = \frac{1}{2} \left[x \cdot \frac{1}{2} (4r^2 - x^2)^{-1/2} \cdot (0 - 2x) + (4r^2 - x^2)^{1/2} \cdot 1 \right]$$

$$= \frac{1}{2} \left[\frac{-2x^2}{2\sqrt{4r^2 - x^2}} + (4r^2 - x^2)^{1/2} \right]$$

$$= \frac{1}{2} \left[\frac{-x^2}{\sqrt{4r^2 - x^2}} + \sqrt{4r^2 - x^2} \right]$$

$$= \frac{1}{2} \left[\frac{-x^2 + 4r^2 - x^2}{\sqrt{4r^2 - x^2}} \right] = \frac{1}{2} \left[\frac{-2x^2 + 4r^2}{\sqrt{4r^2 - x^2}} \right]$$

$$\Rightarrow \frac{dA}{dx} = \left[\frac{-x^2 + 2r^2}{\sqrt{4r^2 - x^2}} \right]$$

Now, $\frac{dA}{dx} = 0$

$$\Rightarrow -x^2 + 2r^2 = 0$$

$$\Rightarrow r^2 = \frac{1}{2} x^2$$

$$\Rightarrow r = \frac{1}{\sqrt{2}} x$$

$$\therefore x = r\sqrt{2}$$

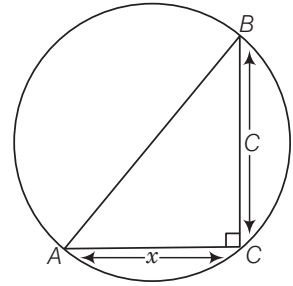

Again, differentiating both sides w.r.t. x , we get

$$\frac{d^2A}{dx^2} = \frac{\sqrt{4r^2 - x^2} \cdot (-2x) + (2r^2 - x^2) \cdot \frac{1}{2} (4r^2 - x^2)^{-1/2} (-2x)}{(\sqrt{4r^2 - x^2})^2}$$

$$= \frac{-2x \left[\sqrt{4r^2 - x^2} + (2r^2 - x^2) \cdot \frac{1}{2\sqrt{4r^2 - x^2}} \right]}{(\sqrt{4r^2 - x^2})^2}$$

$$= \frac{-4x \cdot \left(\sqrt{4r^2 - x^2} \right)^2 + (2r^2 - x^2) (-2x)}{2 \cdot (4r^2 - x^2)^{3/2}}$$

$$= \frac{-4x(4r^2 - x^2) + (2r^2 - x^2) \cdot (-2x)}{2 \cdot (4r^2 - x^2)^{3/2}}$$

$$= \frac{-16xr^2 + 4x^3 + (2r^2 - x^2) (-2x)}{2 \cdot (4r^2 - x^2)^{3/2}}$$

$$\left(\frac{d^2A}{dx^2} \right)_{x=r\sqrt{2}} = \frac{-16 \cdot r\sqrt{2} \cdot r^2 + 4 \cdot (r\sqrt{2})^3 + [2r^2 - (r\sqrt{2})^2] \cdot (-2 \cdot r\sqrt{2})}{2 \cdot (4r^2 - 2r^2)^{3/2}} \quad [\because x = r\sqrt{2}]$$

$$= \frac{-16\sqrt{2} \cdot r^3 + 8\sqrt{2}r^3}{2(2r^2)^{3/2}} = \frac{8\sqrt{2} r^2 [r - 2r]}{4r^3}$$

$$= \frac{-8\sqrt{2} r^3}{4r^3} = -2\sqrt{2} < 0$$

For $x = r\sqrt{2}$, the area of triangle is maximum.

$$\text{For } x = r\sqrt{2}, \quad y = \sqrt{4r^2 - (r\sqrt{2})^2} = \sqrt{2r^2} = r\sqrt{2}$$

$$\text{Since,} \quad x = r\sqrt{2} = y$$

Hence, the triangle is isosceles.

Q. 33 A metal box with a square base and vertical sides is to contain 1024 cm^3 . If the material for the top and bottom costs ₹ 5 per cm^2 and the material for the sides costs ₹ 2.50 per cm^2 . Then, find the least cost of the box.

Sol. Since, volume of the box = 1024 cm^3
Let length of the side of square base be $x \text{ cm}$ and height of the box be $y \text{ cm}$.

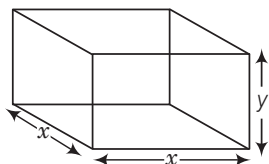

$$\therefore \text{Volume of the box } (V) = x^2 \cdot y = 1024$$

$$\text{Since, } x^2 y = 1024 \Rightarrow y = \frac{1024}{x^2}$$

Let C denotes the cost of the box.

$$\begin{aligned} \therefore C &= 2x^2 \times 5 + 4xy \times 2.50 \\ &= 10x^2 + 10xy = 10x(x + y) \\ &= 10x \left(x + \frac{1024}{x^2} \right) \\ &= \frac{10x}{x^2} (x^3 + 1024) \end{aligned}$$

$$\Rightarrow C = 10x^2 + \frac{10240}{x} \quad \dots (i)$$

On differentiating both sides w.r.t. x , we get

$$\begin{aligned} \frac{dC}{dx} &= 20x + 10240(-x)^{-2} \\ &= 20x - \frac{10240}{x^2} \quad \dots (ii) \end{aligned}$$

$$\text{Now, } \frac{dC}{dx} = 0$$

$$\Rightarrow 20x = \frac{10240}{x^2}$$

$$\Rightarrow 20x^3 = 10240$$

$$\Rightarrow x^3 = 512 = 8^3 \Rightarrow x = 8$$

Again, differentiating Eq. (ii) w.r.t. x , we get

$$\begin{aligned} \frac{d^2C}{dx^2} &= 20 - 10240(-2) \cdot \frac{1}{x^3} \\ &= 20 + \frac{20480}{x^3} > 0 \end{aligned}$$

$$\therefore \left(\frac{d^2C}{dx^2} \right)_{x=8} = 20 + \frac{20480}{512} = 60 > 0$$

For $x = 8$, cost is minimum and the corresponding least cost of the box,

$$\begin{aligned} C(8) &= 10 \cdot 8^2 + \frac{10240}{8} \\ &= 640 + 1280 = 1920 \end{aligned}$$

\therefore Least cost = ₹ 1920

Q. 34 The sum of surface areas of a rectangular parallelepiped with sides x , $2x$ and $\frac{x}{3}$ and a sphere is given to be constant. Prove that the sum of their volumes is minimum, if x is equal to three times the radius of the sphere. Also, find the minimum value of the sum of their volumes.

Sol. We have given that, the sum of the surface areas of a rectangular parallelepiped with sides x , $2x$ and $\frac{x}{3}$ and a sphere is constant.

Let S be the sum of both the surface area.

$$\begin{aligned} \therefore S &= 2 \left(x \cdot 2x + 2x \cdot \frac{x}{3} + \frac{x}{3} \cdot x \right) + 4\pi r^2 = k \\ k &= 2 \left[2x^2 + \frac{2x^2}{3} + \frac{x^2}{3} \right] + 4\pi r^2 \\ &= 2 [3x^2] + 4\pi r^2 = 6x^2 + 4\pi r^2 \\ \Rightarrow 4\pi r^2 &= k - 6x^2 \\ \Rightarrow r^2 &= \frac{k - 6x^2}{4\pi} \\ \Rightarrow r &= \sqrt{\frac{k - 6x^2}{4\pi}} \quad \dots (i) \end{aligned}$$

Let V denotes the volume of both the parallelepiped and the sphere.

$$\begin{aligned} \text{Then, } V &= 2x \cdot x \cdot \frac{x}{3} + \frac{4}{3} \pi r^3 = \frac{2}{3} x^3 + \frac{4}{3} \pi r^3 \\ &= \frac{2}{3} x^3 + \frac{4}{3} \pi \left(\frac{k - 6x^2}{4\pi} \right)^{3/2} \\ &= \frac{2}{3} x^3 + \frac{4}{3} \pi \cdot \frac{1}{8\pi^{3/2}} (k - 6x^2)^{3/2} \\ &= \frac{2}{3} x^3 + \frac{1}{6\sqrt{\pi}} (k - 6x^2)^{3/2} \quad \dots (ii) \end{aligned}$$

On differentiating both sides w.r.t. x , we get

$$\begin{aligned} \frac{dV}{dx} &= \frac{2}{3} \cdot 3x^2 + \frac{1}{6\sqrt{\pi}} \cdot \frac{3}{2} (k - 6x^2)^{1/2} \cdot (-12x) \\ &= 2x^2 - \frac{12x}{4\sqrt{\pi}} \sqrt{k - 6x^2} \\ &= 2x^2 - \frac{3x}{\sqrt{\pi}} (k - 6x^2)^{1/2} \quad \dots (iii) \\ \therefore \frac{dV}{dx} &= 0 \\ \Rightarrow 2x^2 &= \frac{3x}{\sqrt{\pi}} (k - 6x^2)^{1/2} \\ \Rightarrow 4x^4 &= \frac{9x^2}{\pi} (k - 6x^2) \\ \Rightarrow 4\pi x^4 &= 9kx^2 - 54x^4 \\ \Rightarrow 4\pi x^4 + 54x^4 &= 9kx^2 \\ \Rightarrow x^4 [4\pi + 54] &= 9 \cdot k \cdot x^2 \\ \Rightarrow x^2 &= \frac{9k}{4\pi + 54} \\ \Rightarrow x &= 3 \cdot \sqrt{\frac{k}{4\pi + 54}} \quad \dots (iv) \end{aligned}$$

Again, differentiating Eq. (iii) w.r.t. x , we get

$$\begin{aligned}\frac{d^2V}{dx^2} &= 4x - \frac{3}{\sqrt{\pi}} \left[x \cdot \frac{1}{2} (k - 6x^2)^{-1/2} \cdot (-12x) + (k - 6x^2)^{1/2} \cdot 1 \right] \\ &= 4x - \frac{3}{\sqrt{\pi}} [-6x^2 \cdot (k - 6x^2)^{-1/2} + (k - 6x^2)^{1/2}] \\ &= 4x - \frac{3}{\sqrt{\pi}} \left[\frac{-6x^2 + k - 6x^2}{\sqrt{k - 6x^2}} \right] \\ &= 4x - \frac{3}{\sqrt{\pi}} \left[\frac{k - 12x^2}{\sqrt{k - 6x^2}} \right]\end{aligned}$$

$$\begin{aligned}\text{Now, } \left(\frac{d^2V}{dx^2} \right)_{x=3 \cdot \sqrt{\frac{k}{4\pi+54}}} &= 4 \cdot 3 \sqrt{\frac{k}{4\pi+54}} - \frac{3}{\sqrt{\pi}} \left[\frac{k - 12 \cdot 9 \cdot \frac{k}{4\pi+54}}{\sqrt{k - \frac{6 \cdot 9 \cdot k}{4\pi+54}}} \right] \\ &= 12 \sqrt{\frac{k}{4\pi+54}} - \frac{3}{\sqrt{\pi}} \left[\frac{k - \frac{108k}{4\pi+54}}{\sqrt{k - \frac{54k}{4\pi+54}}} \right] \\ &= 12 \sqrt{\frac{k}{4\pi+54}} - \frac{3}{\sqrt{\pi}} \left[\frac{4k\pi + 54k - 108k / 4\pi + 54}{\sqrt{4k\pi + 54k - 54k / 4\pi + 54}} \right] \\ &= 12 \sqrt{\frac{k}{4\pi+54}} - \frac{3}{\sqrt{\pi}} \left[\frac{4k\pi - 54k}{\sqrt{4k\pi} \sqrt{4\pi + 54}} \right] \\ &= 12 \sqrt{\frac{k}{4\pi+54}} - \frac{6}{\sqrt{\pi}} \left[\frac{k(2\pi - 27)}{\sqrt{k} \sqrt{16\pi^2 + 216\pi}} \right] \\ &\quad \left[\text{since, } (2\pi - 27) < 0 \Rightarrow \frac{d^2V}{dx^2} > 0; k > 0 \right]\end{aligned}$$

For $x = 3 \sqrt{\frac{k}{4\pi+54}}$, the sum of volumes is minimum.

$$\text{For } x = 3 \sqrt{\frac{k}{4\pi+54}}, \text{ then } r = \sqrt{\frac{k - 6x^2}{4\pi}} \quad \text{[using Eq. (i)]}$$

$$\begin{aligned}&= \frac{1}{2\sqrt{\pi}} \sqrt{k - 6 \cdot \frac{9k}{4\pi+54}} \\ &= \frac{1}{2\sqrt{\pi}} \cdot \sqrt{\frac{4k\pi + 54k - 54k}{4\pi+54}} \\ &= \frac{1}{2\sqrt{\pi}} \sqrt{\frac{4k\pi}{4\pi+54}} = \frac{\sqrt{k}}{\sqrt{4\pi+54}} = \frac{1}{3} x\end{aligned}$$

$$\Rightarrow x = 3r$$

Hence proved.

\therefore Minimum sum of volume,

$$\begin{aligned}V_{\left(x=3 \cdot \sqrt{\frac{k}{4\pi+54}}\right)} &= \frac{2}{3} x^3 + \frac{4}{3} \pi r^3 = \frac{2}{3} x^3 + \frac{4}{3} \pi \cdot \left(\frac{1}{3} x\right)^3 \\ &= \frac{2}{3} x^3 + \frac{4}{3} \pi \cdot \frac{x^3}{27} = \frac{2}{3} x^3 \left(1 + \frac{2\pi}{27}\right)\end{aligned}$$

Objective Type Questions

- Q. 35** If the sides of an equilateral triangle are increasing at the rate of 2 cm/s then the rate at which the area increases, when side is 10 cm, is
- (a) $10 \text{ cm}^2/\text{s}$ (b) $\sqrt{3} \text{ cm}^2/\text{s}$
 (c) $10\sqrt{3} \text{ cm}^2/\text{s}$ (d) $\frac{10}{3} \text{ cm}^2/\text{s}$

Sol. (c) Let the side of an equilateral triangle be x cm.

$$\therefore \text{Area of equilateral triangle, } A = \frac{\sqrt{3}}{4} x^2 \quad \dots(i)$$

Also, $\frac{dx}{dt} = 2 \text{ cm/s}$

On differentiating Eq. (i) w.r.t. t , we get

$$\begin{aligned} \frac{dA}{dt} &= \frac{\sqrt{3}}{4} \cdot 2x \cdot \frac{dx}{dt} \\ &= \frac{\sqrt{3}}{4} \cdot 2 \cdot 10 \cdot 2 \quad \left[\because x = 10 \text{ and } \frac{dx}{dt} = 2 \right] \\ &= 10\sqrt{3} \text{ cm}^2/\text{s} \end{aligned}$$

- Q. 36** A ladder, 5 m long, standing on a horizontal floor, leans against a vertical wall. If the top of the ladder slides downwards at the rate of 10 cm/s, then the rate at which the angle between the floor and the ladder is decreasing when lower end of ladder is 2 m from the wall is
- (a) $\frac{1}{10} \text{ rad/s}$ (b) $\frac{1}{20} \text{ rad/s}$
 (c) 20 rad/s (d) 10 rad/s

Sol. (b) Let the angle between floor and the ladder be θ .

Let $AB = x$ cm and $BC = y$ cm

$$\therefore \sin \theta = \frac{x}{500} \text{ and } \cos \theta = \frac{y}{500}$$

$$\Rightarrow x = 500 \sin \theta \text{ and } y = 500 \cos \theta$$

Also, $\frac{dx}{dt} = 10 \text{ cm/s}$

$$\Rightarrow 500 \cdot \cos \theta \cdot \frac{d\theta}{dt} = 10 \text{ cm/s}$$

$$\Rightarrow \frac{d\theta}{dt} = \frac{10}{500 \cos \theta} = \frac{1}{50 \cos \theta}$$

For $y = 2 \text{ m} = 200 \text{ cm}$,

$$\begin{aligned} \frac{d\theta}{dt} &= \frac{1}{50 \cdot \frac{y}{500}} = \frac{10}{y} \\ &= \frac{10}{200} = \frac{1}{20} \text{ rad/s} \end{aligned}$$

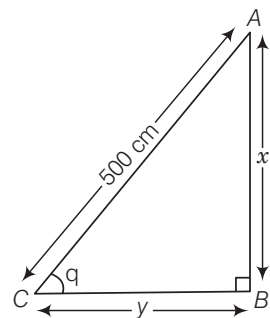

Q. 37 The curve $y = x^{1/5}$ has at $(0, 0)$

- (a) a vertical tangent (parallel to Y-axis)
- (b) a horizontal tangent (parallel to X-axis)
- (c) an oblique tangent
- (d) no tangent

Sol. (a) We have,

$$y = x^{1/5}$$

$$\Rightarrow \frac{dy}{dx} = \frac{1}{5}x^{\frac{1}{5}-1} = \frac{1}{5}x^{-4/5}$$

$$\therefore \left(\frac{dy}{dx}\right)_{(0,0)} = \frac{1}{5} \times (0)^{-4/5} = \infty$$

So, the curve $y = x^{1/5}$ has a vertical tangent at $(0, 0)$, which is parallel to Y-axis.

Q. 38 The equation of normal to the curve $3x^2 - y^2 = 8$ which is parallel to the line $x + 3y = 8$ is

- (a) $3x - y = 8$
- (b) $3x + y + 8 = 0$
- (c) $x + 3y \pm 8 = 0$
- (d) $x + 3y = 0$

Sol. (c) We have, the equation of the curve is $3x^2 - y^2 = 8$... (i)

Also, the given equation of the line is $x + 3y = 8$.

$$\Rightarrow 3y = 8 - x$$

$$\Rightarrow y = -\frac{x}{3} + \frac{8}{3}$$

Thus, slope of the line is $-\frac{1}{3}$ which should be equal to slope of the equation of normal to the curve.

On differentiating Eq. (i) w.r.t. x , we get

$$6x - 2y \frac{dy}{dx} = 0$$

$$\Rightarrow \frac{dy}{dx} = \frac{6x}{2y} = \frac{3x}{y} = \text{Slope of the curve}$$

$$\text{Now, slope of normal to the curve} = -\frac{1}{\left(\frac{dy}{dx}\right)}$$

$$= -\frac{1}{\left(\frac{3x}{y}\right)} = -\frac{y}{3x}$$

$$\therefore -\left(\frac{y}{3x}\right) = -\frac{1}{3}$$

$$\Rightarrow -3y = -3x$$

$$\Rightarrow y = x$$

On substituting the value of the given equation of the curve, we get

$$3x^2 - x^2 = 8$$

$$\Rightarrow x^2 = \frac{8}{2}$$

$$\Rightarrow x = \pm 2$$

For $x = 2$, $3(2)^2 - y^2 = 8$

$\Rightarrow y^2 = 4$

$\Rightarrow y = \pm 2$

and for $x = -2$, $3(-2)^2 - y^2 = 8$

$\Rightarrow y = \pm 2$

So, the points at which normals are parallel to the given line are $(\pm 2, \pm 2)$.

Hence, the equation of normal at $(\pm 2, \pm 2)$ is

$$y - (\pm 2) = -\frac{1}{3}[x - (\pm 2)]$$

$\Rightarrow 3[y - (\pm 2)] = -[x - (\pm 2)]$

$\Rightarrow x + 3y \pm 8 = 0$

Q. 39 If the curve $ay + x^2 = 7$ and $x^3 = y$, cut orthogonally at $(1, 1)$, then the value of a is

- (a) 1 (b) 0 (c) -6 (d) 6

Sol. (d) We have, $ay + x^2 = 7$ and $x^3 = y$

On differentiating w.r.t. x in both equations, we get

$$a \cdot \frac{dy}{dx} + 2x = 0 \quad \text{and} \quad 3x^2 = \frac{dy}{dx}$$

$\Rightarrow \frac{dy}{dx} = -\frac{2x}{a} \quad \text{and} \quad \frac{dy}{dx} = 3x^2$

$\Rightarrow \left(\frac{dy}{dx}\right)_{(1,1)} = \frac{-2}{a} = m_1$

and $\left(\frac{dy}{dx}\right)_{(1,1)} = 3 \cdot 1 = 3 = m_2$

Since, the curves cut orthogonally at $(1, 1)$.

$\therefore m_1 \cdot m_2 = -1$

$\Rightarrow \left(\frac{-2}{a}\right) \cdot 3 = -1$

$\therefore a = 6$

Q. 40 If $y = x^4 - 10$ and x changes from 2 to 1.99, then what is the change in y ?

- (a) 0.32 (b) 0.032 (c) 5.68 (d) 5.968

Sol. (a) We have, $y = x^4 - 10 \Rightarrow \frac{dy}{dx} = 4x^3$

and $\Delta x = 2.00 - 1.99 = 0.01$

$\therefore \Delta y = \frac{dy}{dx} \times \Delta x$

$$= 4x^3 \times \Delta x$$

$$= 4 \times 2^3 \times 0.01$$

$$= 32 \times 0.01 = 0.32$$

So, the approximate change in y is 0.32.

Q. 41 The equation of tangent to the curve $y(1 + x^2) = 2 - x$, where it crosses X -axis, is

(a) $x + 5y = 2$

(b) $x - 5y = 2$

(c) $5x - y = 2$

(d) $5x + y = 2$

Sol. (a) We have, equation of the curve $y(1 + x^2) = 2 - x$... (i)

$$\therefore y \cdot (0 + 2x) + (1 + x^2) \cdot \frac{dy}{dx} = 0 - 1 \quad \text{[on differentiating w.r.t. } x \text{]}$$

$$\Rightarrow 2xy + (1 + x^2) \frac{dy}{dx} = -1$$

$$\Rightarrow \frac{dy}{dx} = \frac{-1 - 2xy}{1 + x^2} \quad \dots \text{(ii)}$$

Since, the given curve passes through X -axis *i.e.*, $y = 0$.

$$\therefore 0(1 + x^2) = 2 - x \quad \text{[using Eq. (i)]}$$

$$\Rightarrow x = 2$$

So, the curve passes through the point $(2, 0)$.

$$\therefore \left(\frac{dy}{dx} \right)_{(2, 0)} = \frac{-1 - 2 \times 0}{1 + 2^2} = -\frac{1}{5} = \text{Slope of the curve}$$

$$\therefore \text{Slope of tangent to the curve} = -\frac{1}{5}$$

\therefore Equation of tangent of the curve passing through $(2, 0)$ is

$$y - 0 = -\frac{1}{5}(x - 2)$$

$$\Rightarrow y + \frac{x}{5} = +\frac{2}{5}$$

$$\Rightarrow 5y + x = 2$$

Q. 42 The points at which the tangents to the curve $y = x^3 - 12x + 18$ are parallel to X -axis are

(a) $(2, -2), (-2, -34)$

(b) $(2, 34), (-2, 0)$

(c) $(0, 34), (-2, 0)$

(d) $(2, 2), (-2, 34)$

Sol. (d) The given equation of curve is

$$y = x^3 - 12x + 18$$

$$\therefore \frac{dy}{dx} = 3x^2 - 12 \quad \text{[on differentiating w.r.t. } x \text{]}$$

So, the slope of line parallel to the X -axis.

$$\therefore \left(\frac{dy}{dx} \right) = 0$$

$$\Rightarrow 3x^2 - 12 = 0$$

$$\Rightarrow x^2 = \frac{12}{3} = 4$$

$$\therefore x = \pm 2$$

$$\text{For } x = 2, \quad y = 2^3 - 12 \times 2 + 18 = 2$$

$$\text{and for } x = -2, \quad y = (-2)^3 - 12(-2) + 18 = 34$$

So, the points are $(2, 2)$ and $(-2, 34)$.

Q. 43 The tangent to the curve $y = e^{2x}$ at the point $(0, 1)$ meets X -axis at

- (a) $(0, 1)$ (b) $\left(-\frac{1}{2}, 0\right)$ (c) $(2, 0)$ (d) $(0, 2)$

Sol. (b) The equation of curve is $y = e^{2x}$
Since, it passes through the point $(0, 1)$.

$$\therefore \frac{dy}{dx} = e^{2x} \cdot 2 = 2 \cdot e^{2x}$$

$$\Rightarrow \left(\frac{dy}{dx}\right)_{(0,1)} = 2 \cdot e^{2 \cdot 0} = 2 = \text{Slope of tangent to the curve}$$

\therefore Equation of tangent is $y - 1 = 2(x - 0)$

$$\Rightarrow y = 2x + 1$$

Since, tangent to curve $y = e^{2x}$ at the point $(0, 1)$ meets X -axis *i.e.*, $y = 0$.

$$\therefore 0 = 2x + 1 \Rightarrow x = -\frac{1}{2}$$

So, the required point is $\left(-\frac{1}{2}, 0\right)$.

Q. 44 The slope of tangent to the curve $x = t^2 + 3t - 8$ and $y = 2t^2 - 2t - 5$ at the point $(2, -1)$ is

- (a) $\frac{22}{7}$ (b) $\frac{6}{7}$ (c) $-\frac{6}{7}$ (d) -6

Sol. (b) Equation of curve is given by

$$x = t^2 + 3t - 8 \quad \text{and} \quad y = 2t^2 - 2t - 5.$$

$$\therefore \frac{dx}{dt} = 2t + 3 \quad \text{and} \quad \frac{dy}{dt} = 4t - 2$$

$$\Rightarrow \frac{dy}{dx} = \frac{\frac{dy}{dt}}{\frac{dx}{dt}} = \frac{4t - 2}{2t + 3} \quad \dots(i)$$

Since, the curve passes through the point $(2, -1)$.

$$\therefore 2 = t^2 + 3t - 8$$

$$\text{and} \quad -1 = 2t^2 - 2t - 5$$

$$\Rightarrow t^2 + 3t - 10 = 0$$

$$\text{and} \quad 2t^2 - 2t - 4 = 0$$

$$\Rightarrow t^2 + 5t - 2t - 10 = 0$$

$$\text{and} \quad 2t^2 + 2t - 4t - 4 = 0$$

$$\Rightarrow t(t + 5) - 2(t + 5) = 0$$

$$\text{and} \quad 2t(t + 1) - 4(t + 1) = 0$$

$$\Rightarrow (t - 2)(t + 5) = 0$$

$$\text{and} \quad (2t - 4)(t + 1) = 0$$

$$\Rightarrow t = 2, -5 \quad \text{and} \quad t = -1, 2$$

$$\Rightarrow t = 2$$

\therefore Slope of tangent,

$$\left(\frac{dy}{dx}\right)_{at\ t=2} = \frac{4 \times 2 - 2}{2 \times 2 + 3} = \frac{6}{7}$$

[using Eq. (i)]

Q. 45 Two curves $x^3 - 3xy^2 + 2 = 0$ and $3x^2y - y^3 - 2 = 0$ intersect at an angle of

- (a) $\frac{\pi}{4}$ (b) $\frac{\pi}{3}$ (c) $\frac{\pi}{2}$ (d) $\frac{\pi}{6}$

Sol. (c) Equation of two curves are given by

$$x^3 - 3xy^2 + 2 = 0$$

and $3x^2y - y^3 - 2 = 0$ [on differentiating w.r.t. x]

$$\Rightarrow 3x^2 - 3 \left[x \cdot 2y \frac{dy}{dx} + y^2 \cdot 1 \right] + 0 = 0$$

$$\text{and } 3 \left[x^2 \frac{dy}{dx} + y \cdot 2x \right] - 3y^2 \frac{dy}{dx} - 0 = 0$$

$$\Rightarrow 3x \cdot 2y \frac{dy}{dx} + 3y^2 = 3x^2$$

$$\text{and } 3y^2 \frac{dy}{dx} = 3x^2 \frac{dy}{dx} + 6xy$$

$$\Rightarrow \frac{dy}{dx} = \frac{3x^2 - 3y^2}{6xy}$$

$$\text{and } \frac{dy}{dx} = \frac{6xy}{3y^2 - 3x^2}$$

$$\Rightarrow \left(\frac{dy}{dx} \right) = \frac{3(x^2 - y^2)}{6xy}$$

$$\text{and } \left(\frac{dy}{dx} \right) = \frac{-6xy}{3(x^2 - y^2)}$$

$$\Rightarrow m_1 = \frac{(x^2 - y^2)}{2xy}$$

$$\text{and } m_2 = \frac{-2xy}{x^2 - y^2}$$

$$\therefore m_1 m_2 = \frac{x^2 - y^2}{2xy} \cdot \frac{-2xy}{x^2 - y^2} = -1$$

Hence, both the curves are intersecting at right angle *i.e.*, making $\frac{\pi}{2}$ with each other.

Q. 46 The interval on which the function $f(x) = 2x^3 + 9x^2 + 12x - 1$ is decreasing is

- (a) $[-1, \infty)$ (b) $[-2, -1]$ (c) $(-\infty, -2]$ (d) $[-1, 1]$

Sol. (b) We have, $f(x) = 2x^3 + 9x^2 + 12x - 1$

$$\therefore f'(x) = 6x^2 + 18x + 12$$

$$= 6(x^2 + 3x + 2) = 6(x + 2)(x + 1)$$

So, $f'(x) \leq 0$, for decreasing.

On drawing number lines as below

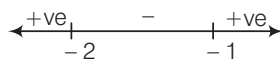

We see that $f'(x)$ is decreasing in $[-2, -1]$.

Q. 47 If $f : R \rightarrow R$ be defined by $f(x) = 2x + \cos x$, then f

- (a) has a minimum at $x = \pi$ (b) has a maximum at $x = 0$
 (c) is a decreasing function (d) is an increasing function

Sol. (d) We have, $f(x) = 2x + \cos x$
 $\therefore f'(x) = 2 + (-\sin x) = 2 - \sin x$
 Since, $f'(x) > 0, \forall x$
 Hence, $f(x)$ is an increasing function.

Q. 48 If $y = x(x-3)^2$ decreases for the values of x given by

- (a) $1 < x < 3$ (b) $x < 0$ (c) $x > 0$ (d) $0 < x < \frac{3}{2}$

Sol. (a) We have, $y = x(x-3)^2$
 $\therefore \frac{dy}{dx} = x \cdot 2(x-3) \cdot 1 + (x-3)^2 \cdot 1$
 $= 2x^2 - 6x + x^2 + 9 - 6x = 3x^2 - 12x + 9$
 $= 3(x^2 - 3x - x + 3) = 3(x-3)(x-1)$

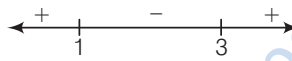

So, $y = x(x-3)^2$ decreases for $(1, 3)$.

[since, $y' < 0$ for all $x \in (1, 3)$, hence y is decreasing on $(1, 3)$]

Q. 49 The function $f(x) = 4\sin^3 x - 6\sin^2 x + 12\sin x + 100$ is strictly

- (a) increasing in $\left(\pi, \frac{3\pi}{2}\right)$ (b) decreasing in $\left(\frac{\pi}{2}, \pi\right)$
 (c) decreasing in $\left[\frac{-\pi}{2}, \frac{\pi}{2}\right]$ (d) decreasing in $\left[0, \frac{\pi}{2}\right]$

Sol. (b) We have, $f(x) = 4\sin^3 x - 6\sin^2 x + 12\sin x + 100$
 $\therefore f'(x) = 12\sin^2 x \cdot \cos x - 12\sin x \cdot \cos x + 12\cos x$
 $= 12[\sin^2 x \cdot \cos x - \sin x \cdot \cos x + \cos x]$
 $= 12\cos x[\sin^2 x - \sin x + 1]$
 $\Rightarrow f'(x) = 12\cos x[\sin^2 x + (1 - \sin x)] \dots(i)$
 $\therefore 1 - \sin x \geq 0$ and $\sin^2 x \geq 0$
 $\therefore \sin^2 x + 1 - \sin x \geq 0$

Hence, $f'(x) > 0$, when $\cos x > 0$ i.e., $x \in \left(-\frac{\pi}{2}, \frac{\pi}{2}\right)$.

So, $f(x)$ is increasing when $x \in \left(-\frac{\pi}{2}, \frac{\pi}{2}\right)$ and $f'(x) < 0$, when $\cos x < 0$ i.e., $x \in \left(\frac{\pi}{2}, \frac{3\pi}{2}\right)$

Hence, $f(x)$ is decreasing when $x \in \left(\frac{\pi}{2}, \frac{3\pi}{2}\right)$

Since, $\left(\frac{\pi}{2}, \pi\right) \in \left(\frac{\pi}{2}, \frac{3\pi}{2}\right)$

Hence, $f(x)$ is decreasing in $\left(\frac{\pi}{2}, \pi\right)$.

Q. 50 Which of the following functions is decreasing on $\left(0, \frac{\pi}{2}\right)$?

- (a) $\sin 2x$ (b) $\tan x$ (c) $\cos x$ (d) $\cos 3x$

Sol. (c) In the interval $\left(0, \frac{\pi}{2}\right)$, $f(x) = \cos x$
 \Rightarrow $f'(x) = -\sin x$
 which gives $f'(x) < 0$ in $\left(0, \frac{\pi}{2}\right)$

Hence, $f(x) = \cos x$ is decreasing in $\left(0, \frac{\pi}{2}\right)$.

Q. 51 The function $f(x) = \tan x - x$

- (a) always increases
 (b) always decreases
 (c) never increases
 (d) sometimes increases and sometimes decreases

Sol. (a) We have, $f(x) = \tan x - x$
 $\therefore f'(x) = \sec^2 x - 1$
 $\Rightarrow f'(x) > 0, \forall x \in \mathbb{R}$
 So, $f(x)$ always increases.

Q. 52 If x is real, then the minimum value of $x^2 - 8x + 17$ is

- (a) -1 (b) 0 (c) 1 (d) 2

Sol. (c) Let $f(x) = x^2 - 8x + 17$
 $\therefore f'(x) = 2x - 8$
 So, $f'(x) = 0$, gives $x = 4$
 Now, $f''(x) = 2 > 0, \forall x$
 So, $x = 4$ is the point of local minima.
 \therefore Minimum value of $f(x)$ at $x = 4$,

$$f(4) = 4 \times 4 - 8 \times 4 + 17 = 1$$

Q. 53 The smallest value of polynomial $x^3 - 18x^2 + 96x$ in $[0, 9]$ is

- (a) 126 (b) 0 (c) 135 (d) 160

Sol. (b) We have, $f(x) = x^3 - 18x^2 + 96x$
 $\therefore f'(x) = 3x^2 - 36x + 96$
 So, $f'(x) = 0$
 Gives, $3x^2 - 36x + 96 = 0$
 $\Rightarrow 3(x^2 - 12x + 32) = 0$
 $\Rightarrow (x - 8)(x - 4) = 0$
 $\Rightarrow x = 8, 4 \in [0, 9]$

We shall now evaluate the value of f at these points and at the end points of the interval $[0, 9]$ i.e., at $x = 4$ and $x = 8$ and at $x = 0$ and at $x = 9$.

$$\begin{aligned} \therefore f(4) &= 4^3 - 18 \cdot 4^2 + 96 \cdot 4 \\ &= 64 - 288 + 384 = 160 \\ f(8) &= 8^3 - 18 \cdot 8^2 + 96 \cdot 8 = 128 \\ f(9) &= 9^3 - 18 \cdot 9^2 + 96 \cdot 9 \\ &= 729 - 1458 + 864 = 135 \end{aligned}$$

and $f(0) = 0^3 - 18 \cdot 0^2 + 96 \cdot 0 = 0$

Thus, we conclude that absolute minimum value of f on $[0, 9]$ is 0 occurring at $x = 0$.

Q. 54 The function $f(x) = 2x^3 - 3x^2 - 12x + 4$, has

- (a) two points of local maximum
- (b) two points of local minimum
- (c) one maxima and one minima
- (d) no maxima or minima

Sol. (c) We have

$$\begin{aligned} f(x) &= 2x^3 - 3x^2 - 12x + 4 \\ \therefore f'(x) &= 6x^2 - 6x - 12 \\ \text{Now, } f'(x) = 0 &\Rightarrow 6(x^2 - x - 2) = 0 \\ \Rightarrow 6(x+1)(x-2) &= 0 \\ \Rightarrow x = -1 \text{ and } x = +2 \end{aligned}$$

On number line for $f'(x)$, we get



Hence $x = -1$ is point of local maxima and $x = 2$ is point of local minima.
So, $f(x)$ has one maxima and one minima.

Q. 55 The maximum value of $\sin x \cdot \cos x$ is

- (a) $\frac{1}{4}$
- (b) $\frac{1}{2}$
- (c) $\sqrt{2}$
- (d) $2\sqrt{2}$

Sol. (b) We have,

$$\begin{aligned} f(x) &= \sin x \cdot \cos x = \frac{1}{2} \sin 2x \\ \therefore f'(x) &= \frac{1}{2} \cdot \cos 2x \cdot 2 = \cos 2x \\ \text{Now, } f'(x) = 0 &\Rightarrow \cos 2x = 0 \\ \Rightarrow \cos 2x = \cos \frac{\pi}{2} &\Rightarrow x = \frac{\pi}{4} \\ \text{Also } f''(x) &= \frac{d}{dx} \cos 2x = -\sin 2x \cdot 2 = -2 \sin 2x \\ \therefore [f''(x)]_{\text{at } x = \pi/4} &= -2 \cdot \sin 2 \cdot \frac{\pi}{4} = -2 \sin \frac{\pi}{2} = -2 < 0 \end{aligned}$$

At $\frac{\pi}{4}$, $f(x)$ is maximum and $\frac{\pi}{4}$ is point of maxima.

$$\therefore f\left(\frac{\pi}{4}\right) = \frac{1}{2} \cdot \sin 2 \cdot \frac{\pi}{4} = \frac{1}{2}$$

Q. 56 At $x = \frac{5\pi}{6}$, $f(x) = 2\sin 3x + 3\cos 3x$ is

- (a) maximum (b) minimum
(c) zero (d) neither maximum nor minimum

Sol. (d) We have, $f(x) = 2\sin 3x + 3\cos 3x$
 $\therefore f'(x) = 2 \cdot \cos 3x \cdot 3 + 3(-\sin 3x) \cdot 3$
 $\Rightarrow f'(x) = 6\cos 3x - 9\sin 3x$... (i)
 Now, $f''(x) = -18\sin 3x - 27\cos 3x$
 $= -9(2\sin 3x + 3\cos 3x)$
 $\therefore f'\left(\frac{5\pi}{6}\right) = 6\cos\left(3 \cdot \frac{5\pi}{6}\right) - 9\sin\left(3 \cdot \frac{5\pi}{6}\right)$
 $= 6\cos\frac{5\pi}{2} - 9\sin\frac{5\pi}{2}$
 $= 6\cos\left(2\pi + \frac{\pi}{2}\right) - 9\sin\left(2\pi + \frac{\pi}{2}\right)$
 $= 0 - 9 \neq 0$
 So, $x = \frac{5\pi}{6}$ cannot be point of maxima or minima.
 Hence, $f(x)$ at $x = \frac{5\pi}{6}$ is neither maximum nor minimum.

Q. 57 The maximum slope of curve $y = -x^3 + 3x^2 + 9x - 27$ is

- (a) 0 (b) 12 (c) 16 (d) 32

Sol. (b) We have, $y = -x^3 + 3x^2 + 9x - 27$
 $\therefore \frac{dy}{dx} = -3x^2 + 6x + 9 = \text{Slope of the curve}$
 and $\frac{d^2y}{dx^2} = -6x + 6 = -6(x-1)$
 $\therefore \frac{d^2y}{dx^2} = 0$
 $\Rightarrow -6(x-1) = 0 \Rightarrow x = 1 > 0$
 Now, $\frac{d^3y}{dx^3} = -6 < 0$
 So, the maximum slope of given curve is at $x = 1$.
 $\therefore \left(\frac{dy}{dx}\right)_{(x=1)} = -3 \cdot 1^2 + 6 \cdot 1 + 9 = 12$

Q. 58 The function $f(x) = x^x$ has a stationary point at

- (a) $x = e$ (b) $x = \frac{1}{e}$ (c) $x = 1$ (d) $x = \sqrt{e}$

Sol. (b) We have, $f(x) = x^x$
 Let $y = x^x$
 and $\log y = x \log x$
 $\therefore \frac{1}{y} \cdot \frac{dy}{dx} = x \cdot \frac{1}{x} + \log x \cdot 1$

$$\Rightarrow \frac{dy}{dx} = (1 + \log x) \cdot x^x$$

$$\therefore \frac{dy}{dx} = 0$$

$$\Rightarrow (1 + \log x) \cdot x^x = 0$$

$$\Rightarrow \log x = -1$$

$$\Rightarrow \log x = \log e^{-1}$$

$$\Rightarrow x = e^{-1}$$

$$\Rightarrow x = \frac{1}{e}$$

Hence, $f(x)$ has a stationary point at $x = \frac{1}{e}$.

Q. 59 The maximum value of $\left(\frac{1}{x}\right)^x$ is

(a) e

(b) e^e

(c) $e^{1/e}$

(d) $\left(\frac{1}{e}\right)^{1/e}$

Sol. (c) Let

$$y = \left(\frac{1}{x}\right)^x$$

$$\Rightarrow \log y = x \cdot \log \frac{1}{x}$$

$$\therefore \frac{1}{y} \cdot \frac{dy}{dx} = x \cdot \frac{1}{x} \cdot \left(-\frac{1}{x^2}\right) + \log \frac{1}{x} \cdot 1$$

$$= -1 + \log \frac{1}{x}$$

$$\therefore \frac{dy}{dx} = \left(\log \frac{1}{x} - 1\right) \cdot \left(\frac{1}{x}\right)^x$$

Now, $\frac{dy}{dx} = 0$

$$\Rightarrow \log \frac{1}{x} = 1 = \log e$$

$$\Rightarrow \frac{1}{x} = e$$

$$\therefore x = \frac{1}{e}$$

Hence, the maximum value of $f\left(\frac{1}{e}\right) = (e)^{1/e}$.

Fillers

Q. 60 The curves $y = 4x^2 + 2x - 8$ and $y = x^3 - x + 13$ touch each other at the point

Sol. The curves $y = 4x^2 + 2x - 8$ and $y = x^3 - x + 13$ touch each other at the point (3, 34).
Given, equation of curves are $y = 4x^2 + 2x - 8$ and $y = x^3 - x + 13$

$$\therefore \frac{dy}{dx} = 8x + 2$$

$$\text{and} \quad \frac{dy}{dx} = 3x^2 - 1$$

So, the slope of both curves should be same

$$\therefore 8x + 2 = 3x^2 - 1$$

$$\Rightarrow 3x^2 - 8x - 3 = 0$$

$$\Rightarrow 3x^2 - 9x + x - 3 = 0$$

$$\Rightarrow 3x(x - 3) + 1(x - 3) = 0$$

$$\Rightarrow (3x + 1)(x - 3) = 0$$

$$\therefore x = -\frac{1}{3} \text{ and } x = 3,$$

$$\begin{aligned} \text{For } x = -\frac{1}{3}, \quad y &= 4 \cdot \left(-\frac{1}{3}\right)^2 + 2 \cdot \left(-\frac{1}{3}\right) - 8 \\ &= \frac{4}{9} - \frac{2}{3} - 8 = \frac{4 - 6 - 72}{9} \\ &= -\frac{74}{9} \end{aligned}$$

$$\begin{aligned} \text{and for } x = 3, y &= 4 \cdot (3)^2 + 2 \cdot (3) - 8 \\ &= 36 + 6 - 8 = 34 \end{aligned}$$

So, the required points are (3, 34) and $\left(-\frac{1}{3}, -\frac{74}{9}\right)$.

Q. 61 The equation of normal to the curve $y = \tan x$ at (0, 0) is

Sol. The equation of normal to the curve $y = \tan x$ at (0, 0) is $x + y = 0$.

$$\therefore y = \tan x \Rightarrow \frac{dy}{dx} = \sec^2 x$$

$$\Rightarrow \left(\frac{dy}{dx}\right)_{(0,0)} = \sec^2 0 = 1 \text{ and } -\frac{1}{\left(\frac{dy}{dx}\right)} = -\frac{1}{1}$$

\therefore Equation of normal to the curve $y = \tan x$ at (0, 0) is

$$y - 0 = -1(x - 0)$$

$$\Rightarrow y + x = 0$$

Q. 62 The values of a for which the function $f(x) = \sin x - ax + b$ increases on R are

Sol. The values of a for which the function $f(x) = \sin x - ax + b$ increases on R are $(-\infty, -1)$.

$$\begin{aligned} \therefore & f'(x) = \cos x - a \\ \text{and} & f'(x) > 0 \Rightarrow \cos x > a \\ \text{Since,} & \cos x \in [-1, 1] \\ \Rightarrow & a < -1 \Rightarrow a \in (-\infty, -1) \end{aligned}$$

Q. 63 The function $f(x) = \frac{2x^2 - 1}{x^4}$, (where, $x > 0$) decreases in the interval

Sol. The function $f(x) = \frac{2x^2 - 1}{x^4}$, where $x > 0$, decreases in the interval $(1, \infty)$.

$$\begin{aligned} \therefore f'(x) &= \frac{x^4 \cdot 4x - (2x^2 - 1) \cdot 4x^3}{x^8} = \frac{4x^5 - 8x^5 + 4x^3}{x^8} \\ &= \frac{-4x^5 + 4x^3}{x^8} = \frac{4x^3(-x^2 + 1)}{x^8} \end{aligned}$$

Also, $f'(x) < 0$

$$\Rightarrow \frac{4x^3(1 - x^2)}{x^8} < 0 \Rightarrow x^2 > 1$$

$$\Rightarrow x > \pm 1$$

$$\therefore x \in (1, \infty)$$

Q. 64 The least value of function $f(x) = ax + \frac{b}{x}$ (where, $a > 0, b > 0, x > 0$) is

Sol. The least value of function $f(x) = ax + \frac{b}{x}$ (where, $a > 0, b > 0, x > 0$) is $2\sqrt{ab}$.

$$\therefore f'(x) = a - \frac{b}{x^2} \text{ and } f'(x) = 0$$

$$\Rightarrow a = \frac{b}{x^2}$$

$$\Rightarrow x^2 = \frac{b}{a} \Rightarrow x = \pm \sqrt{\frac{b}{a}}$$

Now, $f''(x) = -b \cdot \frac{(-2)}{x^3} = +\frac{2b}{x^3}$

$$\text{At } x = \sqrt{\frac{b}{a}}, \quad f''(x) = +\frac{2b}{\left(\frac{b}{a}\right)^{3/2}} = +\frac{2b \cdot a^{3/2}}{b^{3/2}}$$

$$= +2b^{-1/2} \cdot a^{3/2} = +2\sqrt{\frac{a^3}{b}} > 0 \quad [\because a, b > 0]$$

$$\begin{aligned} \therefore \text{Least value of } f(x), \quad f\left(\sqrt{\frac{b}{a}}\right) &= a \cdot \sqrt{\frac{b}{a}} + \frac{b}{\sqrt{\frac{b}{a}}} \\ &= a \cdot a^{-1/2} \cdot b^{1/2} + b \cdot b^{-1/2} \cdot a^{1/2} \\ &= \sqrt{ab} + \sqrt{ab} = 2\sqrt{ab} \end{aligned}$$